

Technical data

For wood chip and pellet combustion system

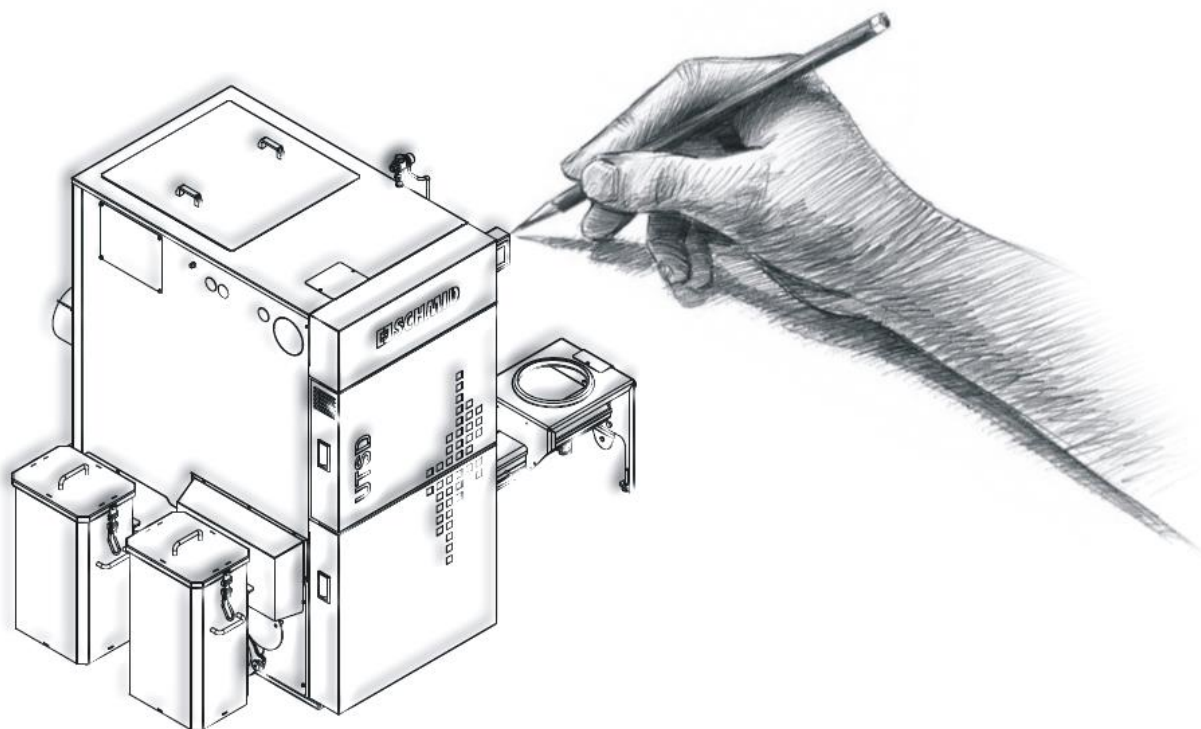

UTSD 240

Table of Contents:

Chapter	Description	Page
1	Brief description of the boiler plant	4
1.1	General	4
1.2	Features and scope of delivery	4
1.2.1	Boiler body	4
1.2.2	Cladding	4
1.2.3	Combustion technology	5
1.2.4	Combustion chamber	5
1.2.5	Standard deashing system	5
1.2.6	Cleaning system	5
1.2.7	Stoker screw unit	5
1.2.8	Safety equipment	6
1.2.9	Control unit	7
2	Technical data	10
2.1	Assignment	10
2.2	Sectional view	11
2.3	Wood chips technical data	12
2.4	Pellets technical data	14
2.5	Feed dimensions	16
2.5.1	Minimum feed dimensions	16
2.5.2	Feed dimension with cladding, partially equipped	17
2.5.3	Feed dimension when delivered	18
2.6	Minimum distances with ash container 50l	19
2.7	Minimum distances with ash container 240l	21
2.8	Minimum room height	23
2.9	Main dimensions / deashing variants UTSD240	24
2.9.1	UTSD240/260 Stoker left, ash container 50l	24
2.9.2	UTSD240/260 Stoker left, ash container 240l at rear	25
2.9.3	UTSD240/260 Stoker left, ash container 240l rear right	26
2.9.4	UTSD240/260 Stoker left, ash container 240l rear left	27

2.9.5	UTSD240/260 Stoker right, ash container 50l.....	28
2.9.6	UTSD240/260 Stoker right, ash container 240l at rear	29
2.9.7	UTSD240/260 Stoker right, ash container 240l rear left.....	30
2.9.8	UTSD240/260 Stoker right, ash container 240l rear right	31
3	Fuel.....	32
3.1	Permissible fuel	32
3.2	Wood chips.....	32
3.3	Wood pellets.....	34
3.4	Permissible fuel according to EN303-5 version 2012-11-15.....	36
3.5	Permissible fuel in accordance with 1. BImSchV.....	36
3.6	Nominal heat output depending on the water content	37
4	Flue.....	39
4.1	Requirements	39
4.2	Flue design data, wood chips	40
4.3	Flue design data, pellets.....	43
5	Transport / securing.....	46
5.1	Transport with a crane.....	46
5.2	Transport with pallet truck	47
5.3	Aligning the boiler.....	47
6	Electrics / mains cable / external units.....	48
6.1	Regulations	48
6.2	Cable routing	48
6.3	Mains connection.....	49
7	Hydraulic requirements	50
7.1	Requirements for circulating water up to 110°	50
7.2	Temperature relief valve (TAS)	51
7.3	Thermally activated extinguishing system	52
7.4	Accumulator	53
7.5	Hydraulic integration.....	55

1 Brief description of the boiler plant

1.1 General

The UTSD system series combines a robust construction, mature combustion technology and reliability with maximum convenience, modern design and innovative control technology.

Due to the standard automatic ignition, the integrated combustion and power control and the available buffer management, these systems fulfil all necessary requirements for ecological and economical operation.

The solid, air-cooled and automatic rotary grate technology with the hot combustion chamber above it, constructed from individual parts, forms the basis for regular and low-emission combustion.

1.2 Features and scope of delivery

Wood chip and pellet combustion system with automatic fuel supply, type approval in compliance with EN303-5:2012
System optionally available in left or right-hand version.

1.2.1 Boiler body

Pressure-tested, welded boiler body made of 4-6mm tested quality steel plate with integrated safety heat exchanger, reinforced with sleeve or tie rods.

1.2.2 Cladding

Boiler cladding made of powder-coated sheet steel, orange (RAL2000), ready-packed with 60-100mm internal insulation.

1.2.3 Combustion technology

Underfeed combustion system fed with stoker unit with heat-resistant rotary grate for wood chips and pellets in accordance with DIN EN ISO 17225 Solid biofuels.

Air control unit for primary and secondary air consisting of two actuator motors and two speed-controlled combustion air blowers, speed-controlled induced draft fan, combustion chamber temperature sensor, optical combustion chamber level and firebed monitoring, flue gas temperature sensor, lambda sensor with protection tube and heat-resistant sealing disc, ignition blower, flow and return line sensors.

1.2.4 Combustion chamber

Individually removable combustion chamber lining made of fired, refractory material which partly forms the secondary air duct, of modular design. The secondary air is supplied through a refractory cast steel nozzle.

1.2.5 Standard deashing system

Consisting of a gear motor, two deashing screws for the grate and fly ash area, two mobile ash containers, each with a volume of 50 litres, and a locking device on the boiler body.

The grate ash and fly ash are automatically compressed and conveyed into the two ash containers. Variable cleaning intervals, can be modified to suit the fuel.

1.2.6 Cleaning system

The cleaning springs and turbulators in the stationary heat exchanger tubes are automatically moved along with the grate deashing system. Cleaning takes place before each boiler start-up.

1.2.7 Stoker screw unit

Stoker screw housing, stoker screw tungsten-coated in the areas subject to wear. Counter bearing, drive motor with torque support.

1.2.8 Safety equipment

- The underpressure in the combustion chamber is monitored over the entire combustion operation and the supply air fans are switched off if the value falls below a certain value.
- The firebed is permanently monitored by light barriers and the fuel supply is switched off when the fuel level exceeds the limit.
- The combustion chamber temperature is permanently monitored by a combustion chamber temperature sensor and switches off the fuel supply if a certain value is exceeded.
- The boiler is equipped with a safety heat exchanger and a thermal process safeguard as well as a safety temperature limiter.
- The fuel supply is equipped with a backfire protection feature (backfire flap or rotary valve).
- On the stoker unit (fuel supply in front of the combustion chamber) there is a temperature sensor which switches off the combustion system if a certain temperature is exceeded and empties the stoker.
- Connection option for the self-actuating extinguishing device (SLE) on the stoker unit.

1.2.9 Control unit

Schmid Automatic Control 3 for fully automatic year-round operation with practical control panel (7" touch display) for combustion monitoring and automatic fuel detection.

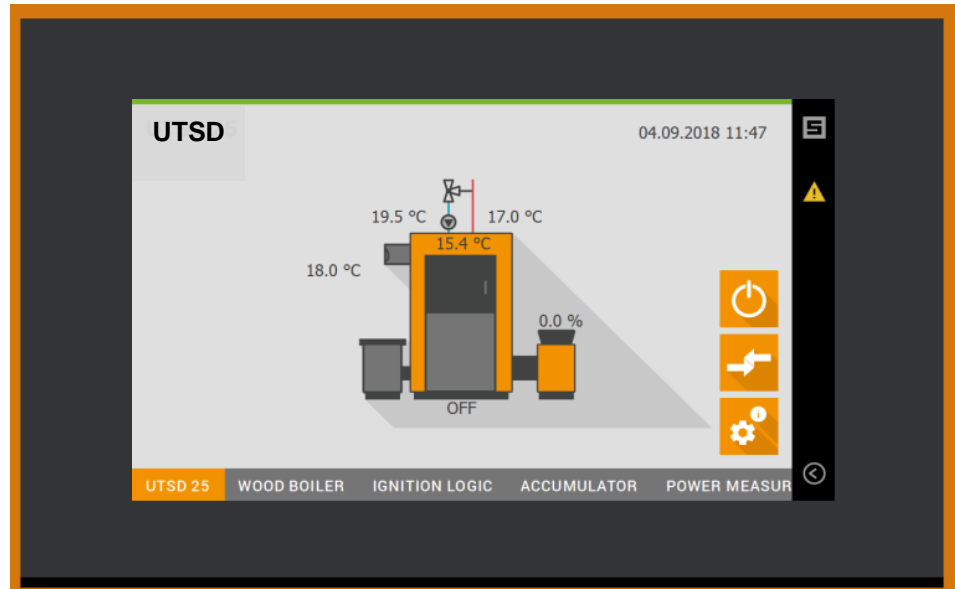

Operating modes

There are eight operating modes to choose from:

According to demand

The heating system starts as soon as a heat consumer in the system requests energy. The heating system is enabled for heat generation until all requirements in the system are fulfilled.

According to buffer temperature

The heating system starts as soon as the upper buffer temperature sensor falls under the set starting temperature. The heating system is enabled for heat generation until the buffer below temperature sensor is higher than the set switch-off temperature.

According to buffer loading level

The heating system starts as soon as the calculated buffer loading level of the buffer storage falls below the set starting threshold. The heating system is enabled for heat generation until the set buffer loading level is reached.

According to boiler temperature

The heating system is released as soon as a heat consumer in the system requests energy. The heating system is regulated to the set boiler temperature. Depending on the heat consumption, the boiler modulates down to the boiler min. Power. The heating system is enabled for heat generation until there is no longer a requirement or the boiler temperature exceeds the set temperature.

According to boiler output

The heating system is released as soon as a heat consumer in the system requests energy. The heating system is regulated to the set boiler output. The heating system is enabled for heat generation until there is no longer a requirement or the boiler temperature max. is exceeded.

According to external boiler temperature

The boiler temperature is preset via an external analog signal. Further operating behavior like "According to boiler temperature"

According to external boiler output

The boiler output is preset via an external analog signal. Further operating behavior like "According to boiler output"



All of the above described operating modes can be released via a separate external digital contact (floating contact). On delivery, the AC3 control unit is preinstalled with a wire jumper on the ST2 Digital IN connector.

Individual equipment option with motor modules:

- Up to 6 modules on the Automatic Control 3 for different applications.
- Can be extended with expansion boards with up to three motor modules (also decentralized, can be installed directly at the units)
- Reversing via current measurement for each motor module
- Motor protection function by means of current measurement (overcurrent and undercurrent detection [phase monitoring]) for each motor module
- Low spare part costs as only the individual module has to be replaced in case of a defect and not the expansion board or the Automatic Control 3

Interfaces:

- Modbus TCP
- Modbus RTU (only possible with additional adapter)

Heat distribution by MultiControl3

2 Technical data

2.1 Assignment

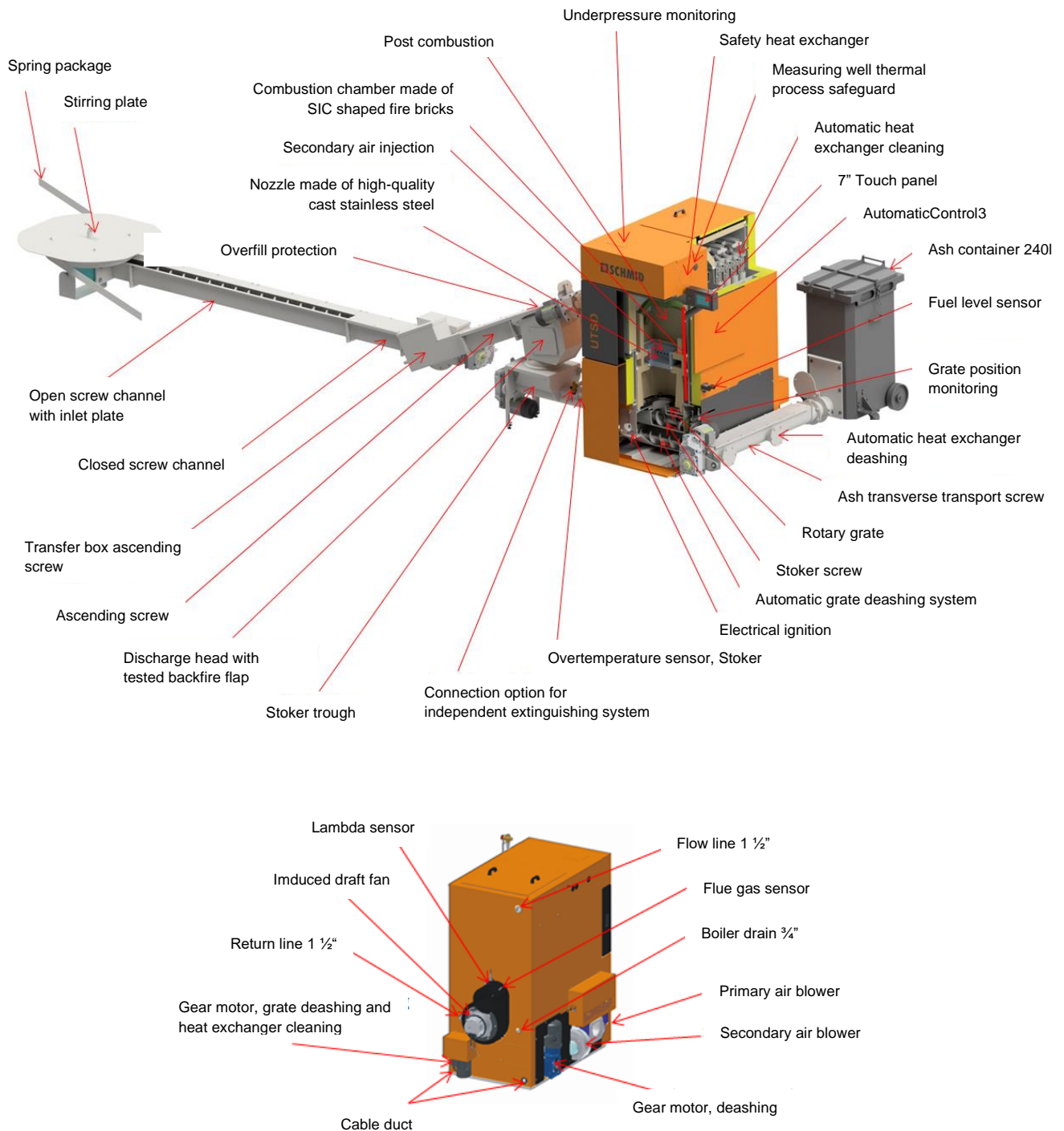

2.2 Sectional view

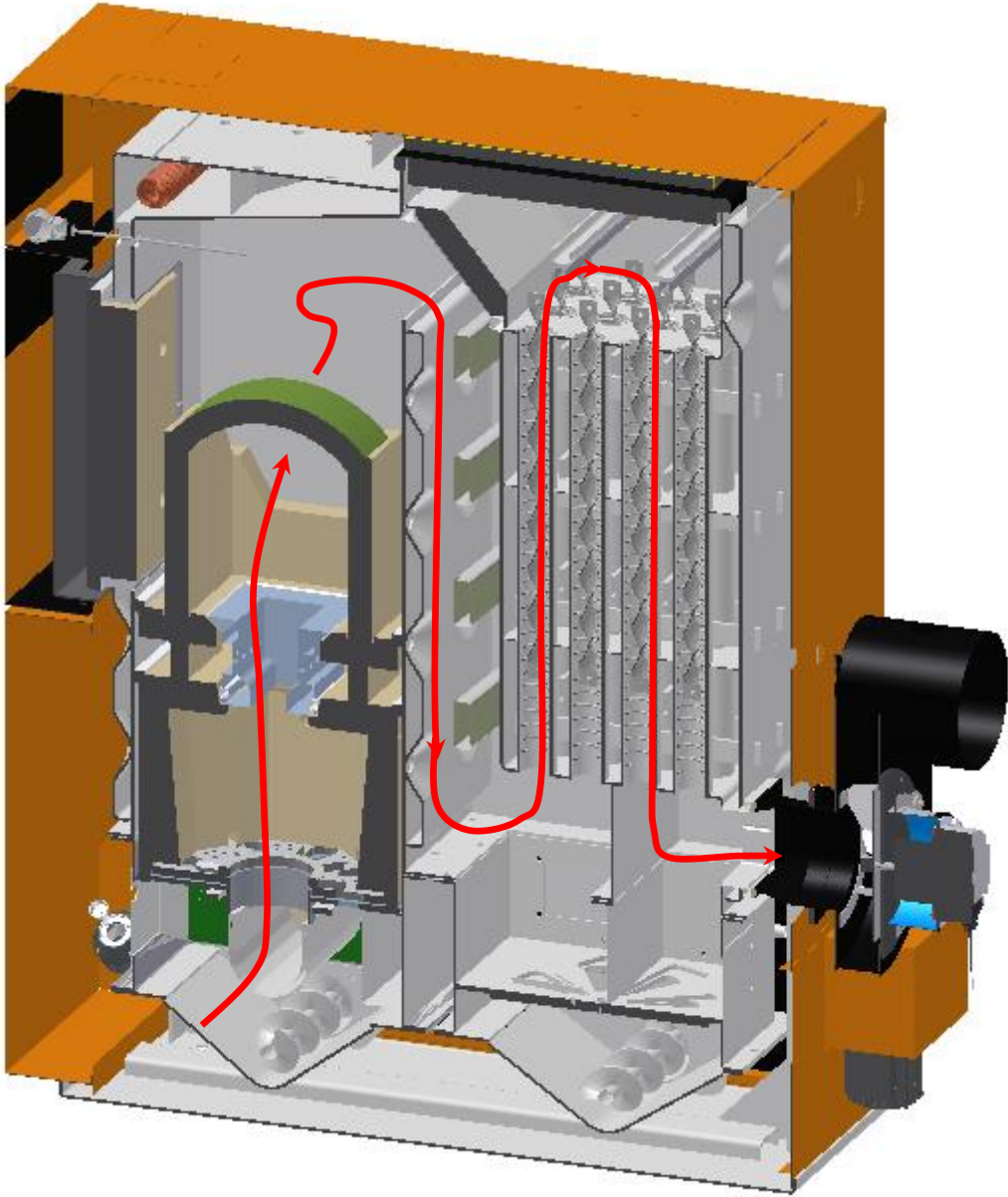

2.3 Wood chips technical data

UTSD 240		240/120	240/140	240/150	240/160	240/180
Nominal heat capacity	kW	120	140	150	160	180
Heat capacity range	kW	35-120	35-140	35-150	35-160	35-180
Combustion capacity	kW	122.5	147.7	158.7	169.7	191.8
Permissible operating overpressure	kPa / bar	300 / 3	300 / 3	300 / 3	300 / 3	300 / 3
Test pressure	kPa / bar	600 / 6	600 / 6	600 / 6	600 / 6	600 / 6
Maximum boiler temperature	°C	95	95	95	95	95
Minimum return line temperature	°C	65	65	65	65	65
Water side resistance at dt 10K	mbar	62.8	93.2	106.6	120.1	146.9
Water side resistance at dt 20K	mbar	16.6	23.4	26.9	30.3	37.2
Boiler water content	Litres	350	350	350	350	350
Heat radiation losses approx.	%	0.8	0.8	0.8	0.8	0.8
Minimum heat consumption	kW	36	42	45	48	54
Flue gas temp. at tested nominal load	°C	97.1	101.3	103.1	105,0	108.6
Flue gas temp. at lowest load	°C	61.1	61.1	61.1	61.1	61.1
Flue gas flow rate at the nominal capacity	g/s	63.5	81.1	88.9	96.6	112.1
Necessary conveying pressure	mbar	0.08	0.08	0.08	0.08	0.08
CO ₂ content	vol-%	15.2	14.2	13.8	13.3	12.5
Flue gas connection diameter	mm	200	200	200	200	200
Therm. process safeguard: Flow rate	m ³ /h	1.5	1.5	1.5	1.5	1.5
Min. pressure	bar	2	2	2	2	2
Max. temperature	°C	20	20	20	20	20
Electrical connection						
Nominal voltage	AC V	3x400	3x400	3x400	3x400	3x400
Frequency	Hz	50	50	50	50	50
Nominal capacity	A	20	20	20	20	20
Nominal capacity	kW	2.2	2.2	2.2	2.2	2.2
Standby capacity	W	14.1	14.1	14.1	14.1	14.1
Required auxiliary electrical energy	W	194.1	246.1	272,0	298,0	350,0
Nominal capacity motor flue gas fan	W	500	500	500	500	500
Noise emission						
Sound pressure level (at distance of 0.5m)	dB(A)	52	52	52	52	52
Sound power level	dB(A)	64	64	64	64	64
Combustion chamber opening dimensions						
Width	mm	506	506	506	506	506
Height	mm	460	460	460	460	460
Boiler weight (without water)	kg	2020	2020	2020	2020	2020

Wood chip and pellet combustion system

UTSD 240

UTSD 240		240/200	240/220	240/240	240/250	240/260
Nominal heat capacity	kW	200	220	240	250	260
Heat capacity range	kW	35-200	35-220	35-240	35-250	35-260
Combustion capacity	kW	213,2	236,3	258,7	269,9	281,5
Permissible operating overpressure	kPa / bar	300 / 3	300 / 3	300 / 3	300 / 3	300 / 3
Test pressure	kPa / bar	600 / 6	600 / 6	600 / 6	600 / 6	600 / 6
Maximum boiler temperature	°C	95	95	95	95	95
Minimum return line temperature	°C	65	65	65	65	65
Water side resistance at dt 10K	mbar	173,7	213,2	252,7	289,1	325,4
Water side resistance at dt 20K	mbar	44,1	53	62,8	68,2	73,5
Boiler water content	Litres	350	350	350	350	350
Heat radiation losses approx.	%	0,8	0,8	0,9	0,9	1,0
Minimum heat consumption	kW	60	66	72	75	78
Flue gas temp. at tested nominal load	°C	112,2	118,7	125,0	128,1	131,4
Flue gas temp. at lowest load	°C	61,1	61,1	61,1	61,1	61,1
Flue gas flow rate at the nominal capac	g/s	127,1	137,7	148,0	153,1	158,5
Necessary conveying pressure	mbar	0,08	0,08	0,08	0,08	0,08
CO ₂ content	vol-%	11,7	12,0	12,3	12,4	12,6
Flue gas connection diameter	mm	200	200	200	200	200
Therm. process safeguard: Flow rate	m ³ /h	1,5	1,5	1,5	1,5	1,5
Min. pressure	bar	2	2	2	2	2
Max. temperature	°C	20	20	20	20	20
Electrical connection						
Nominal voltage	AC V	3x400	3x400	3x400	3x400	3x400
Frequency	Hz	50	50	50	50	50
Nominal capacity	A	20	20	20	20	20
Nominal capacity	kW	2,2	2,2	2,2	2,2	2,2
Standby capacity	W	14,1	14,1	14,1	14,1	14,1
Required auxiliary electrical energy	W	401,9	453,9	505,8	531,8	557,8
Nominal capacity motor flue gas fan	W	500	500	500	500	500
Noise emission						
Sound pressure level (at distance of 0.5	dB(A)	63	63	63	69	69
Sound power level	dB(A)	76	76	76	82	82
Combustion chamber opening dimensions						
Width	mm	506	506	506	506	506
Height	mm	460	460	460	460	460
Boiler weight (without water)	kg	2030	2030	2030	2030	2030

2.4 Pellets technical data

UTSD 240		240/110	240/120	240/140	240/150	240/160	240/180
Nominal heat capacity	kW	110	120	140	150	160	180
Heat capacity range	kW	35-110	35-120	35-140	35-150	35-160	35-180
Combustion capacity	kW	114,2	125,1	146,1	156,7	167,2	188,3
Permissible operating overpressure	kPa / bar	300 / 3	300 / 3	300 / 3	300 / 3	300 / 3	300 / 3
Test pressure	kPa / bar	600 / 6	600 / 6	600 / 6	600 / 6	600 / 6	600 / 6
Maximum boiler temperature	°C	95	95	95	95	95	95
Minimum return line temperature	°C	65	65	65	65	65	65
Water side resistance at dt 10K	mbar	53,0	62,8	93,2	106,6	120,1	146,9
Water side resistance at dt 20K	mbar	13,1	16,6	23,4	26,9	30,3	37,2
Boiler water content	Litres	350	350	350	350	350	350
Heat radiation losses approx.	%	0,4	0,4	0,5	0,6	0,7	0,8
Minimum heat consumption	kW	33	36	42	45	48	54
Flue gas temp. at tested nominal load	°C	84,1	86,2	90,4	92,5	94,6	98,7
Flue gas temp. at lowest load	°C	53,9	53,9	53,9	53,9	53,9	53,9
Flue gas flow rate at the nominal capac	g/s	53,1	61,5	77,8	86,0	94,2	110,5
Necessary conveying pressure	mbar	0,08	0,08	0,08	0,08	0,08	0,08
CO ₂ content	vol-%	15,5	15,1	14,3	13,9	13,5	12,7
Flue gas connection diameter	mm	200	200	200	200	200	200
Therm. process safeguard: Flow rate	m ³ /h	1,5	1,5	1,5	1,5	1,5	1,5
Min. pressure	bar	2	2	2	2	2	2
Max. temperature	°C	20	20	20	20	20	20
Electrical connection							
Nominal voltage	AC V	3x400	3x400	3x400	3x400	3x400	3x400
Frequency	Hz	50	50	50	50	50	50
Nominal capacity	A	20	20	20	20	20	20
Nominal capacity	kW	2,2	2,2	2,2	2,2	2,2	2,2
Standby capacity	W	14,1	14,1	14,1	14,1	14,1	14,1
Required auxiliary electrical energy	W	108,7	131,3	176,5	199,1	221,7	266,9
Nominal capacity motor flue gas fan	W	500	500	500	500	500	500
Noise emission							
Sound pressure level (at distance of 0.5	dB(A)	52	52	52	52	52	52
Sound power level	dB(A)	64	64	64	64	64	64
Combustion chamber opening dimensions							
	Width	mm	506	506	506	506	506
	Height	mm	460	460	460	460	460
Boiler weight (without water)	kg	2020	2020	2020	2020	2020	2020

Wood chip and pellet combustion system

UTSD 240

UTSD 240		240/200	240/220	240/240	240/250	240/260
Nominal heat capacity	kW	200	220	240	250	260
Heat capacity range	kW	35-200	35-220	35-240	35-250	35-260
Combustion capacity	kW	207,9	233,1	256,6	268,4	281,3
Permissible operating overpressure	kPa / bar	300 / 3	300 / 3	300 / 3	300 / 3	300 / 3
Test pressure	kPa / bar	600 / 6	600 / 6	600 / 6	600 / 6	600 / 6
Maximum boiler temperature	°C	95	95	95	95	95
Minimum return line temperature	°C	65	65	65	65	65
Water side resistance at dt 10K	mbar	173,7	213,2	252,7	289,1	325,4
Water side resistance at dt 20K	mbar	44,1	53,0	62,8	68,2	73,5
Boiler water content	Litres	350	350	350	350	350
Heat radiation losses approx.	%	0,9	0,9	0,9	1,0	1,0
Minimum heat consumption	kW	60	66	72	75	78
Flue gas temp. at tested nominal load	°C	106,2	110,1	117,2	120,7	124,6
Flue gas temp. at lowest load	°C	53,9	53,9	53,9	53,9	53,9
Flue gas flow rate at the nominal capac	g/s	125,7	138,9	151,3	157,5	164,3
Necessary conveying pressure	mbar	0,08	0,08	0,08	0,08	0,08
CO ₂ content	vol-%	12,0	12,2	12,3	12,4	12,5
Flue gas connection diameter	mm	200	200	200	200	200
Therm. process safeguard: Flow rate	m ³ /h	1,5	1,5	1,5	1,5	1,5
Min. pressure	bar	2	2	2	2	2
Max. temperature	°C	20	20	20	20	20
Electrical connection						
Nominal voltage	AC V	3x400	3x400	3x400	3x400	3x400
Frequency	Hz	50	50	50	50	50
Nominal capacity	A	20	20	20	20	20
Nominal capacity	kW	2,2	2,2	2,2	2,2	2,2
Standby capacity	W	14,1	14,1	14,1	14,1	14,1
Required auxiliary electrical energy	W	312,0	357,2	402,4	425,0	447,6
Nominal capacity motor flue gas fan	W	500	500	500	500	500
Noise emission						
Sound pressure level (at distance of 0.5	dB(A)	63	63	63	69	69
Sound power level	dB(A)	76	76	76	82	82
Combustion chamber opening dimensions						
Width	mm	506	506	506	506	506
Height	mm	460	460	460	460	460
Boiler weight (without water)	kg	2030	2030	2030	2030	2030

2.5 Feed dimensions

2.5.1 Minimum feed dimensions

The minimum feed dimension according to the drawing is achieved by dismantling the cladding and various attachments. Lower dimensions possible on request.

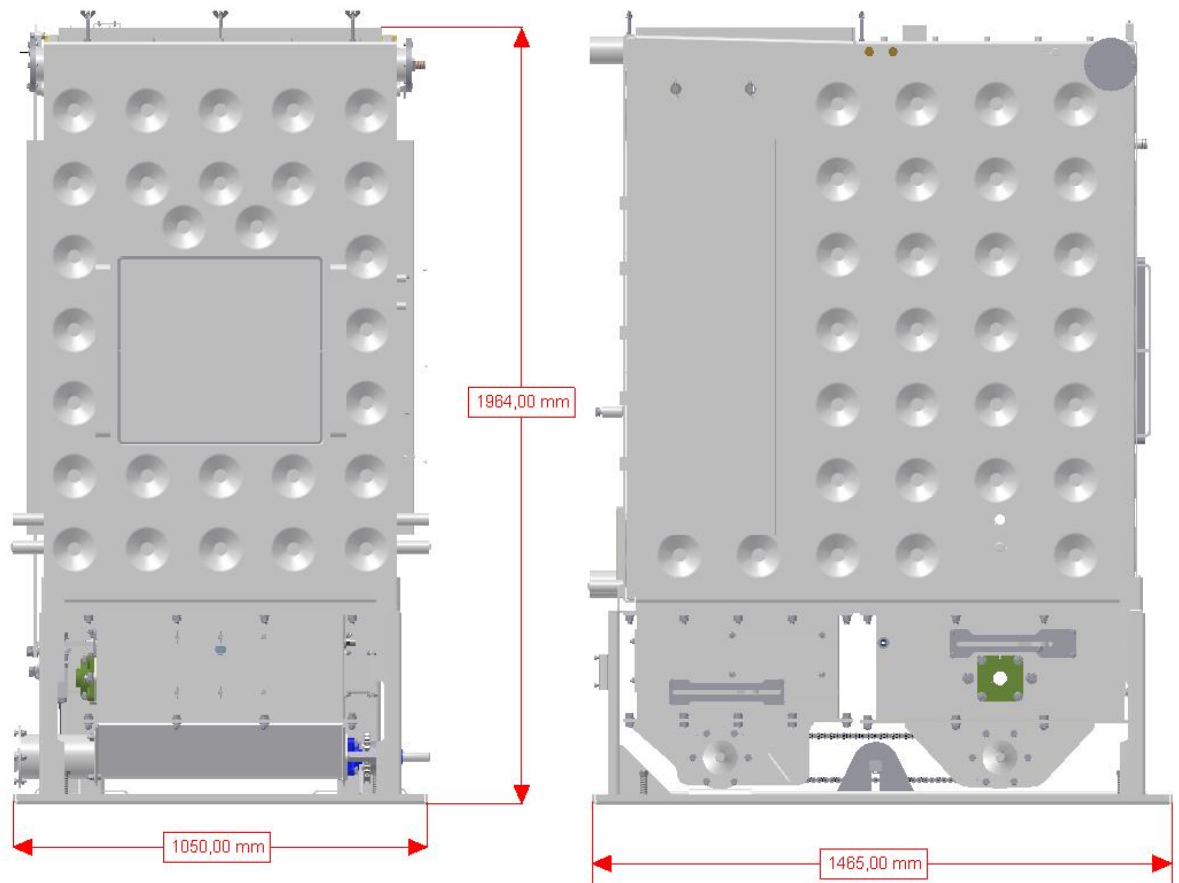

2.5.2 Feed dimension with cladding, partially equipped

By dismantling the main units, such as air control units, flue gas fan, grate drive and deashing motor, the following feed dimensions can be achieved.

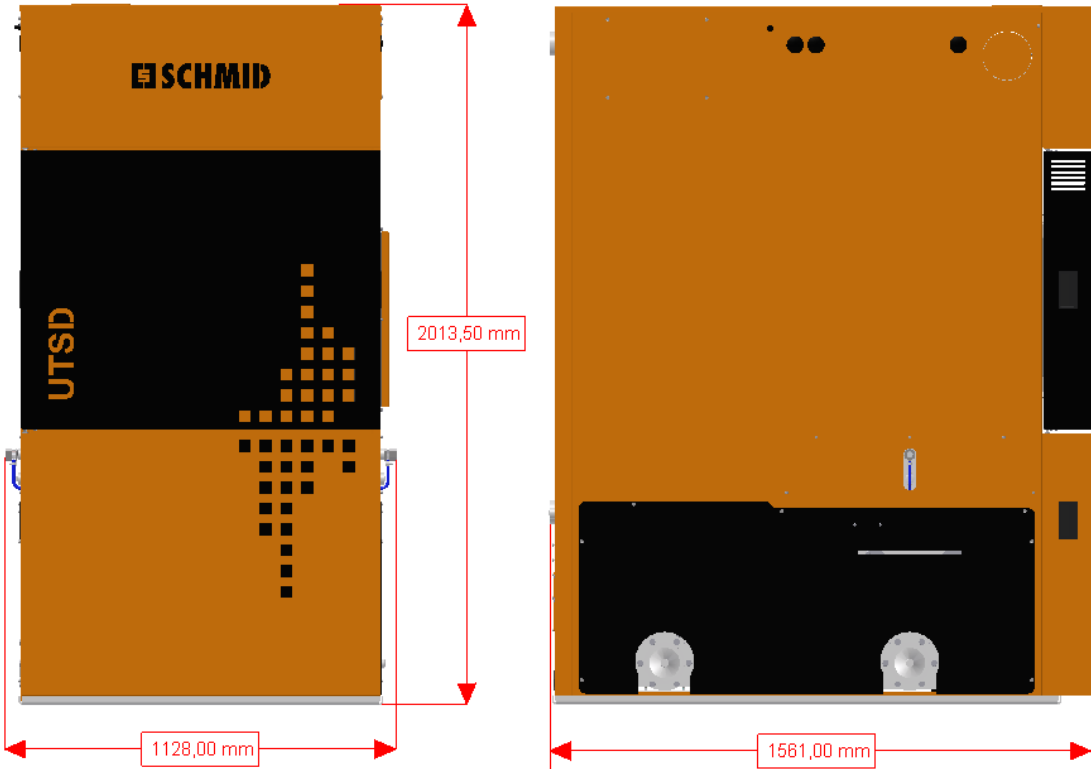

2.5.3 Feed dimension when delivered

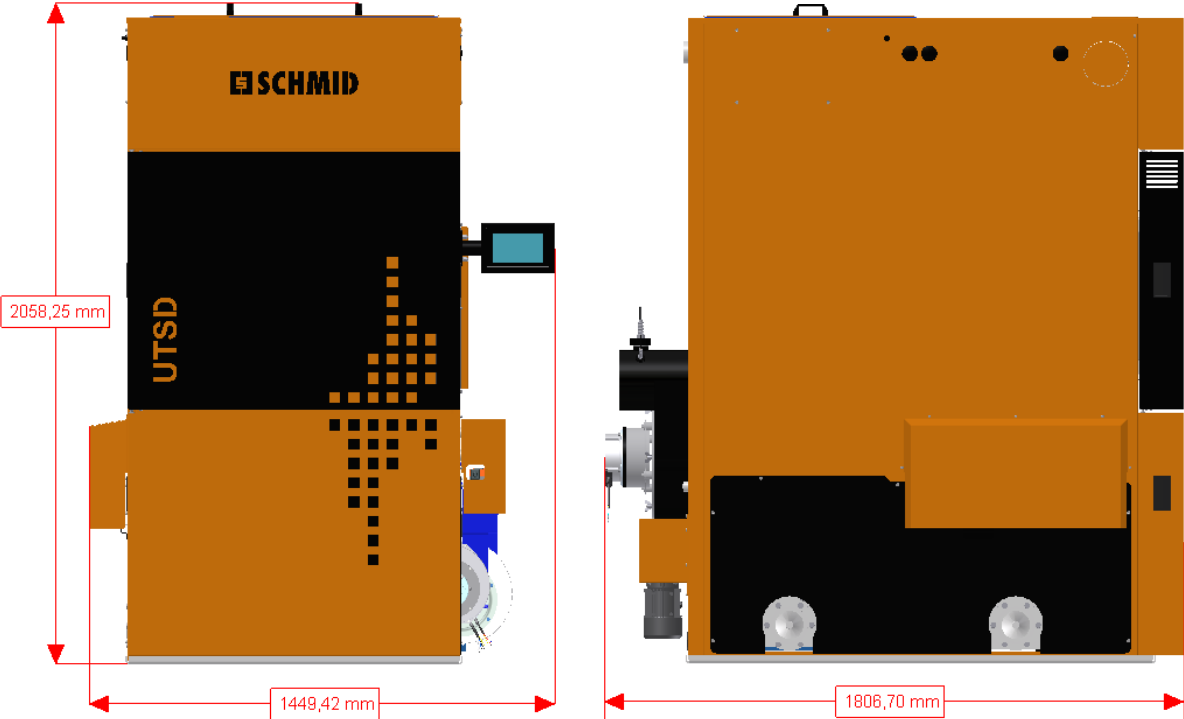

2.6 Minimum distances with ash container 50l

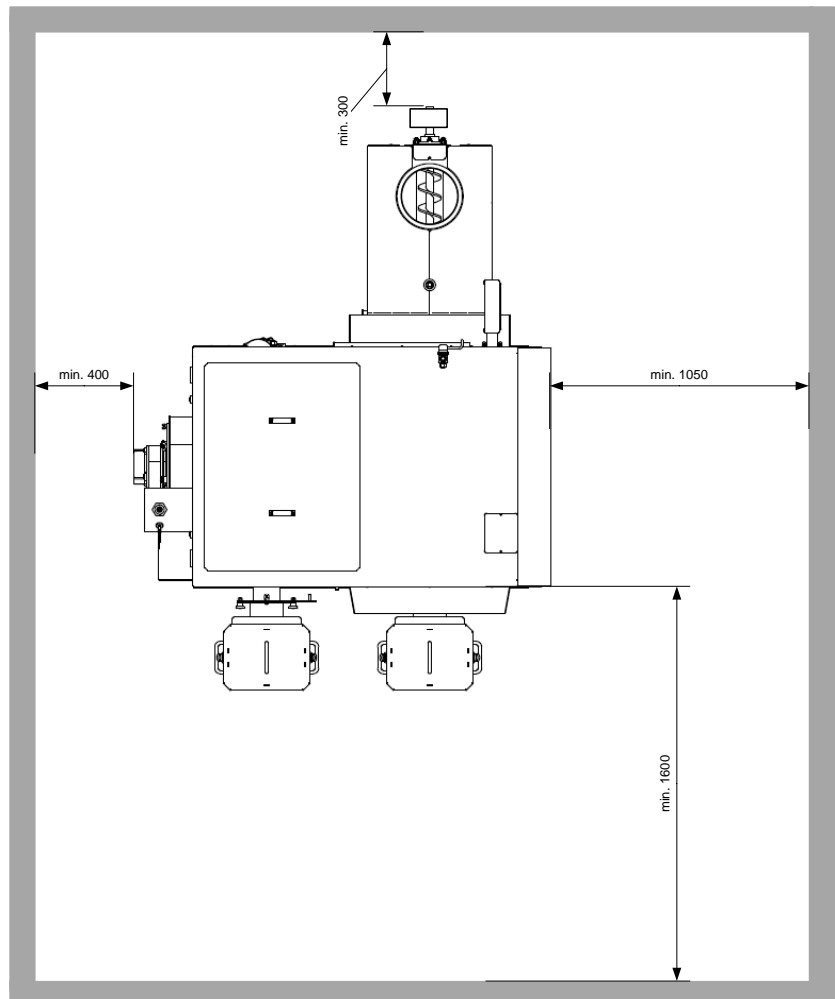

Wood chip and pellet combustion system UTSD 240

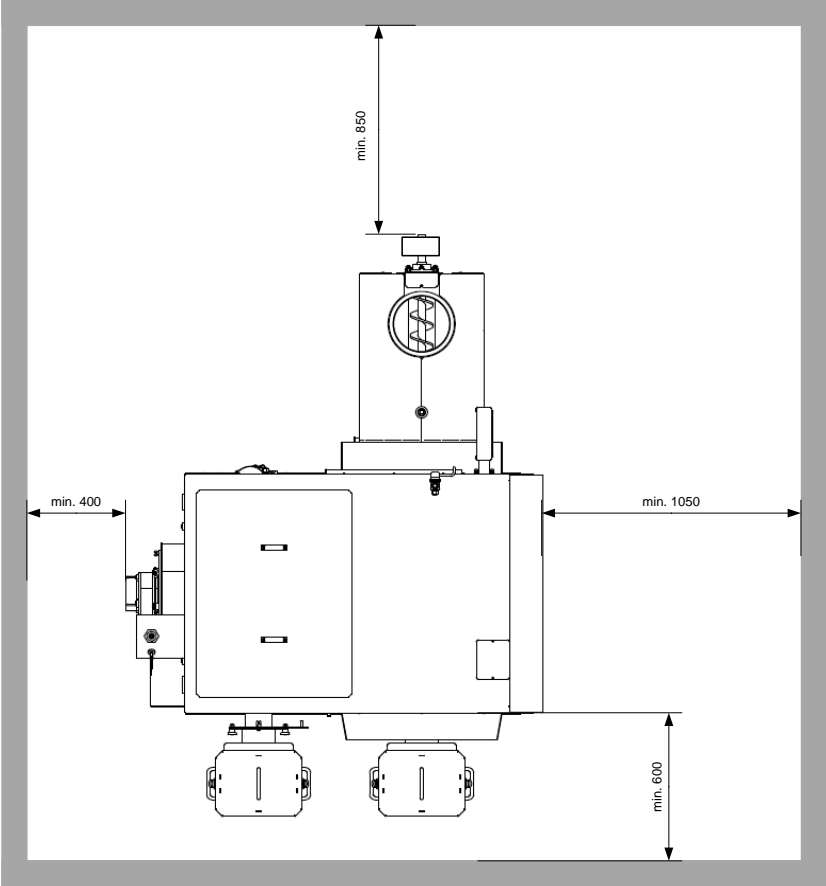

2.7 Minimum distances with ash container 240I

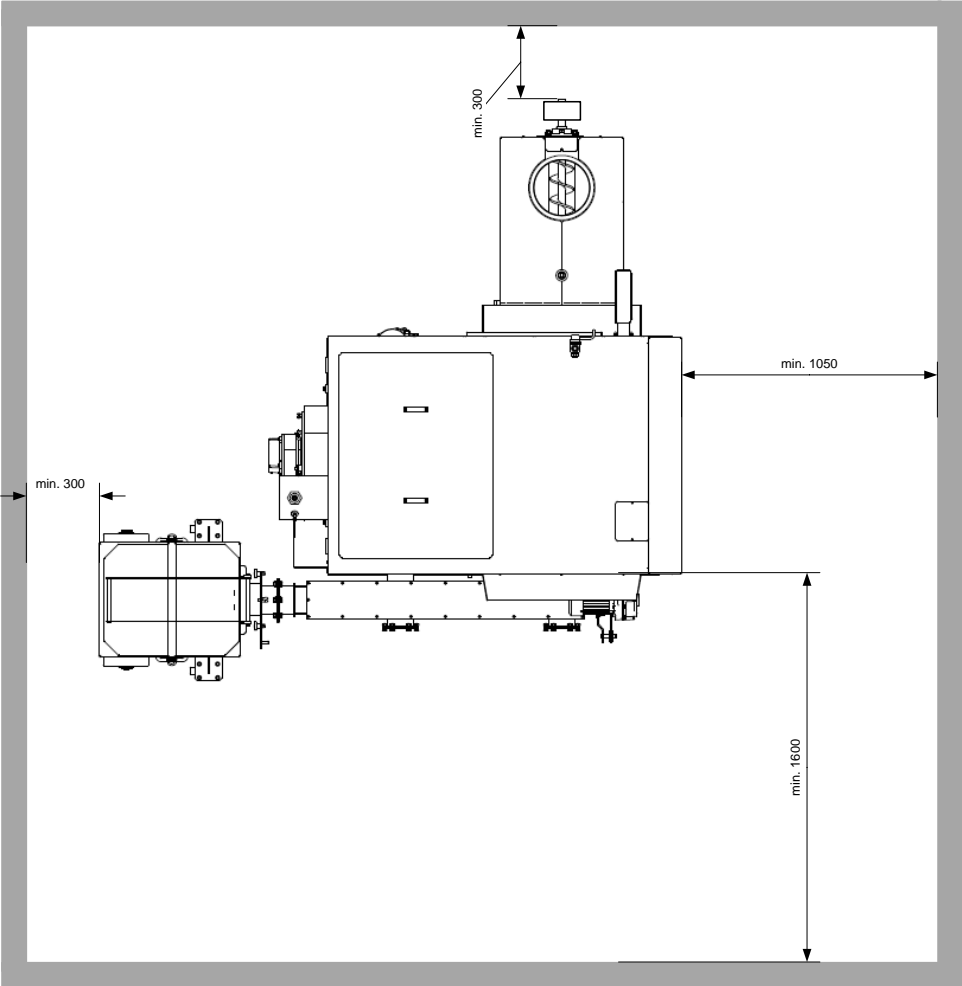

Wood chip and pellet combustion system UTSD 240

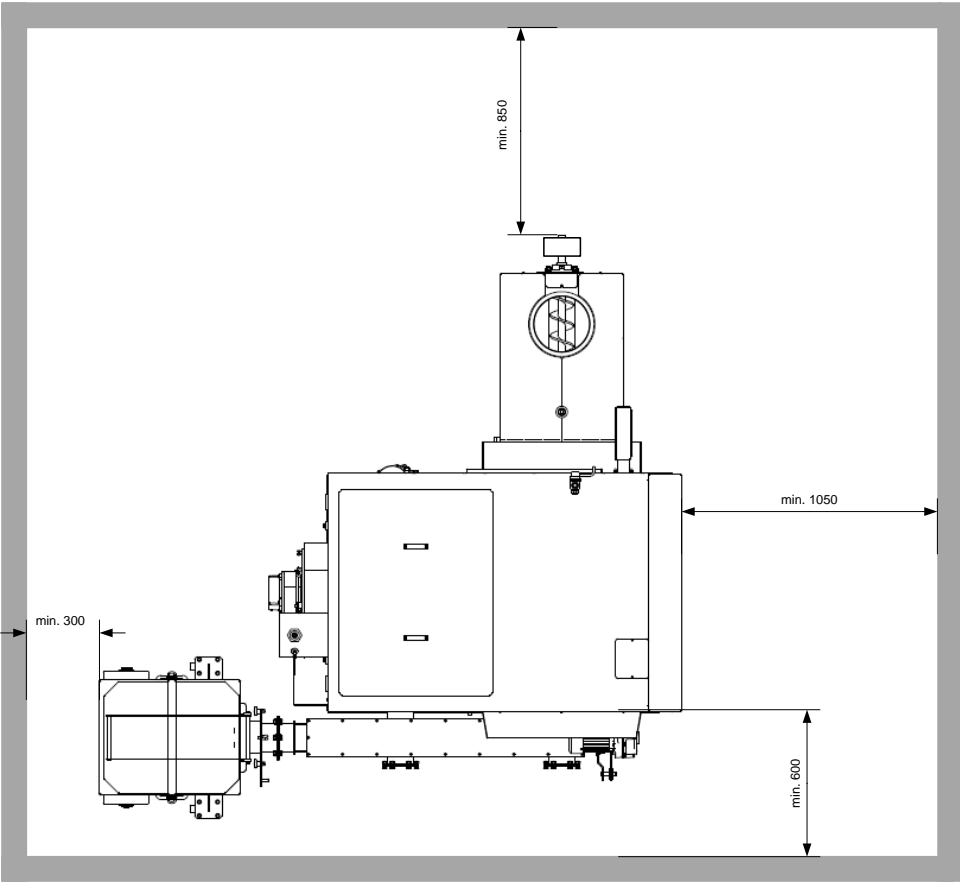

2.8 Minimum room height

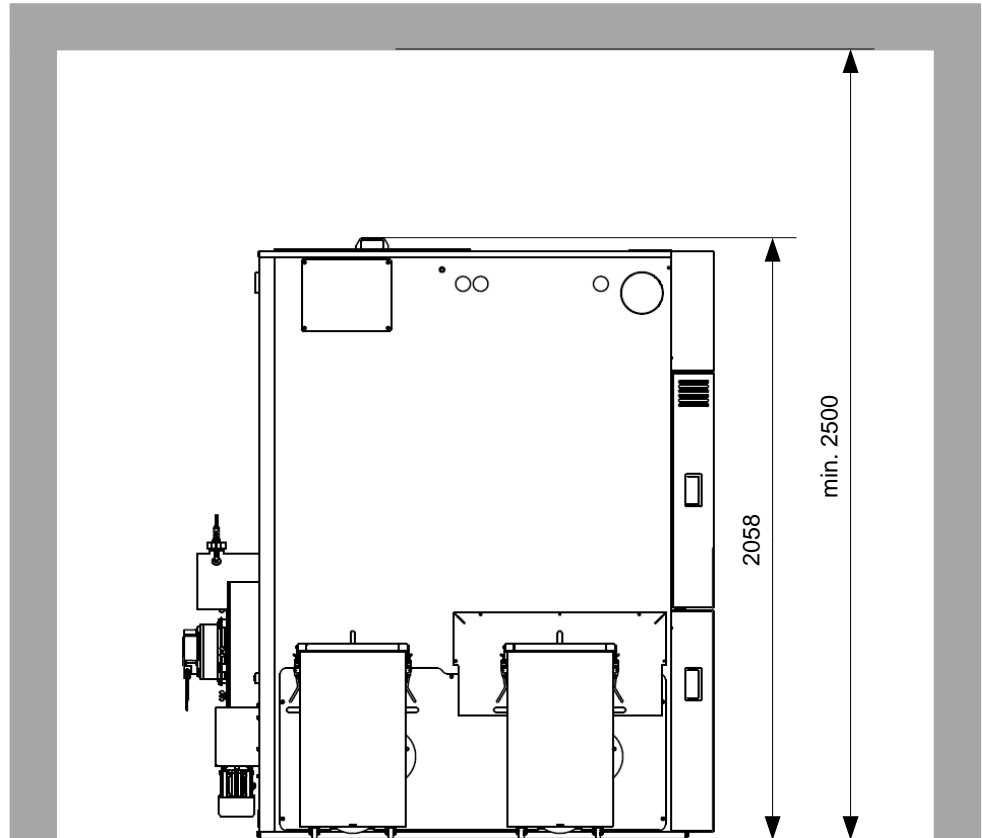

2.9 Main dimensions / deashing variants UTSD240

2.9.1 UTSD240/260 Stoker left, ash container 50l

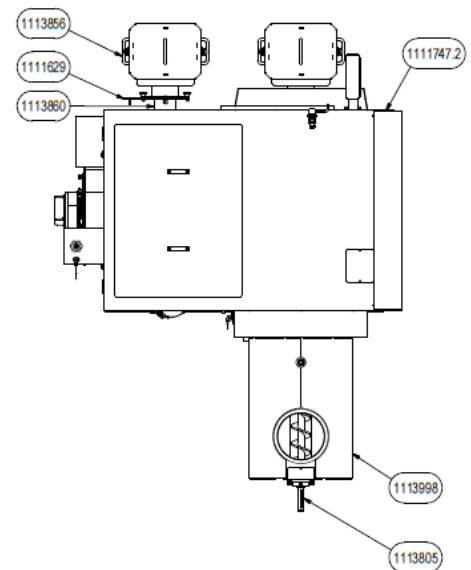
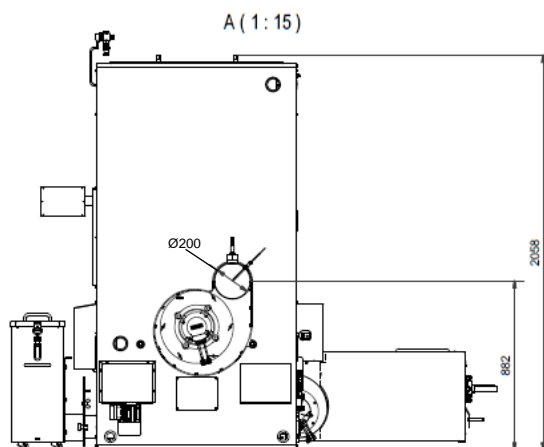
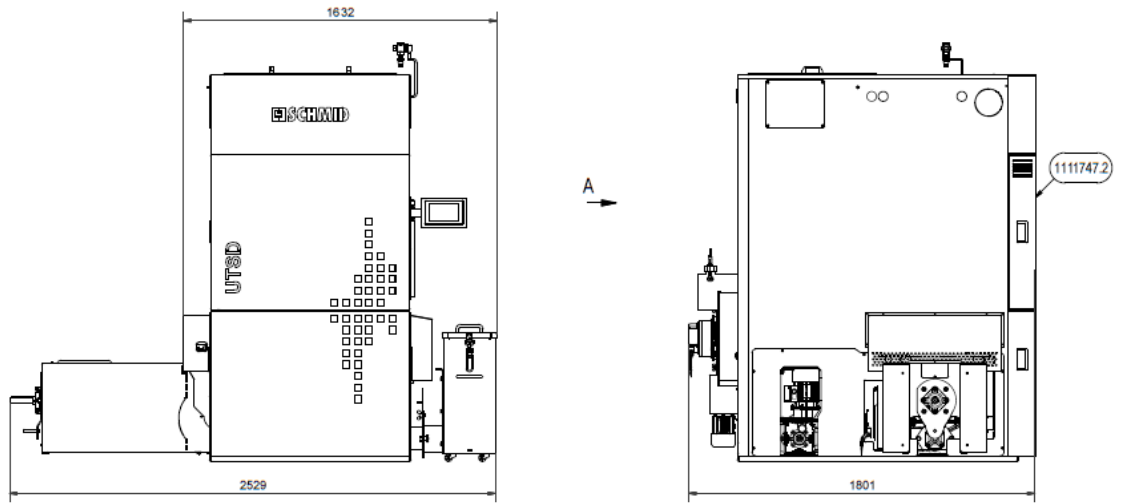

UTSD 240 CH vL (120-260 kW)

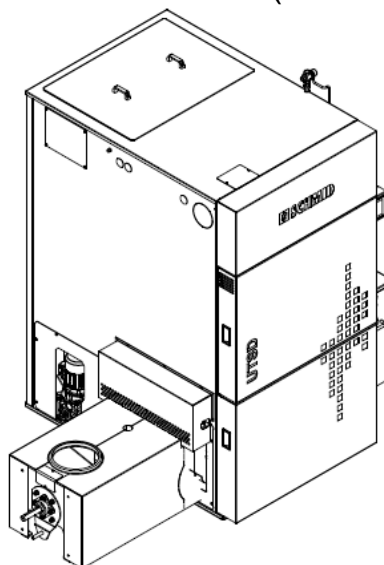

Wood chip and pellet combustion system UTSD 240

2.9.2 UTSD240/260 Stoker left, ash container 240l at rear

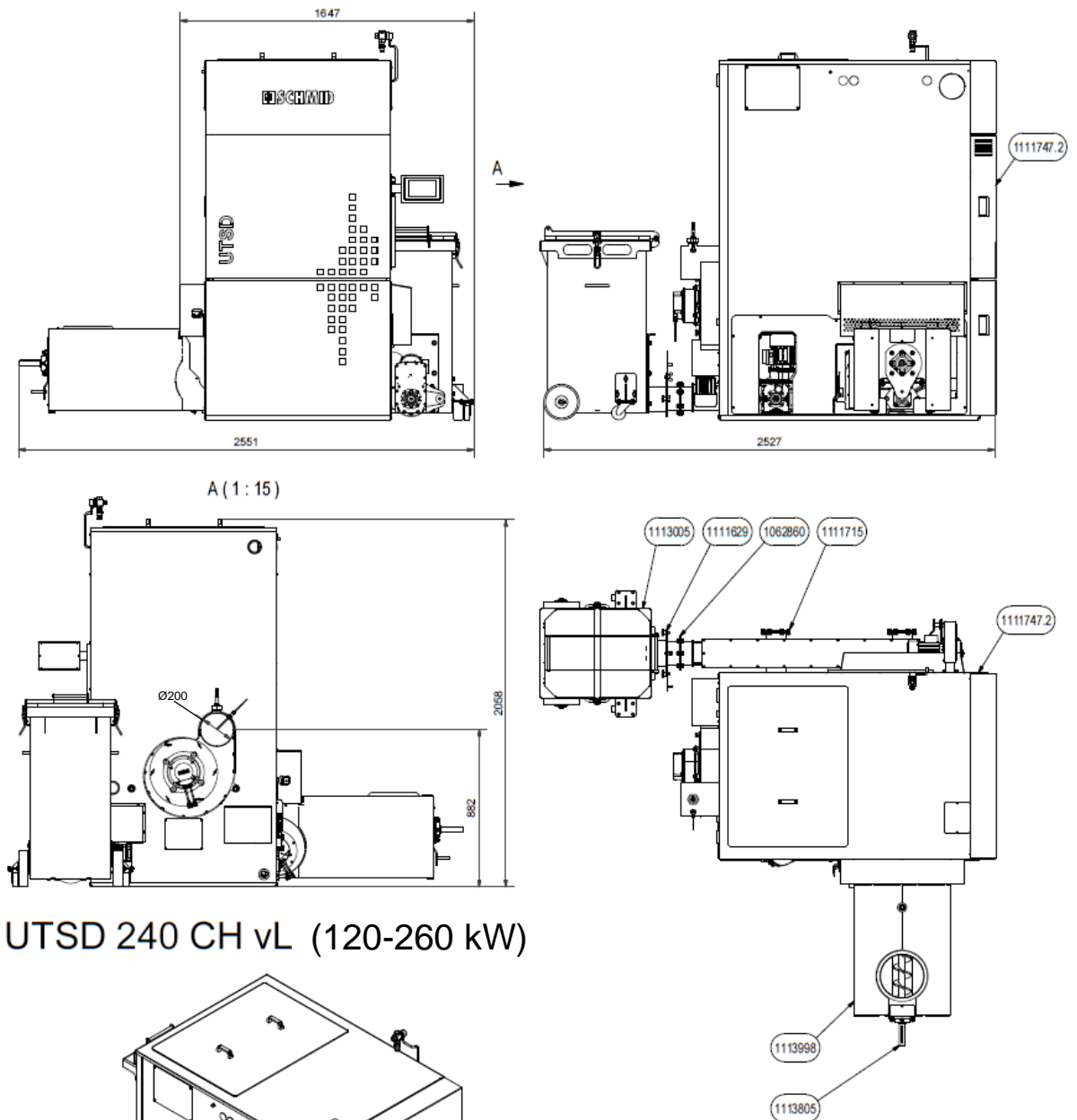

UTSD 240 CH vL (120-260 kW)

2.9.3 UTSD240/260 Stoker left, ash container 240l rear right

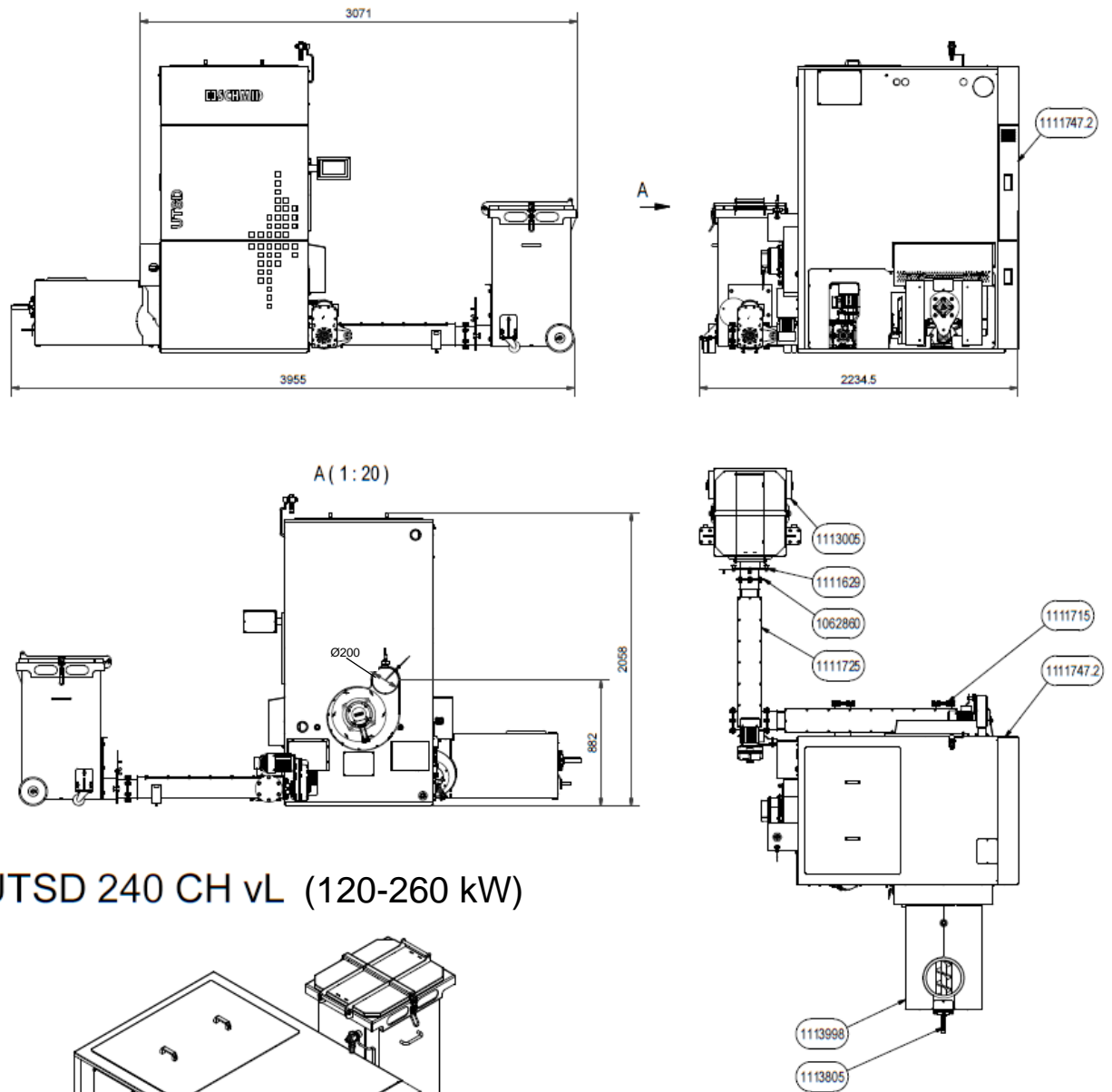

UTSD 240 CH vL (120-260 kW)

2.9.4 UTSD240/260 Stoker left, ash container 240l rear left

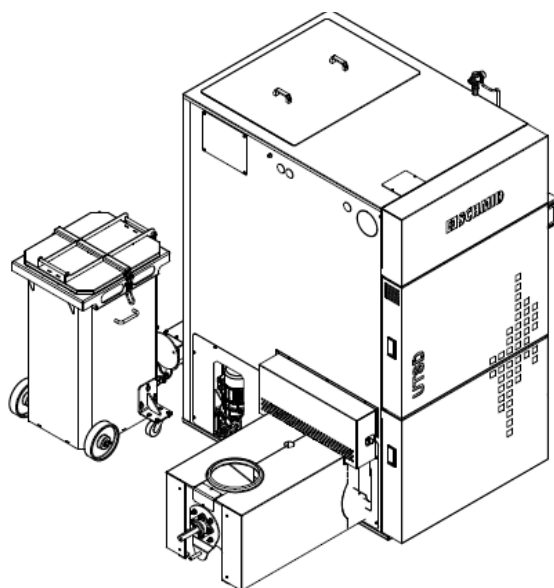
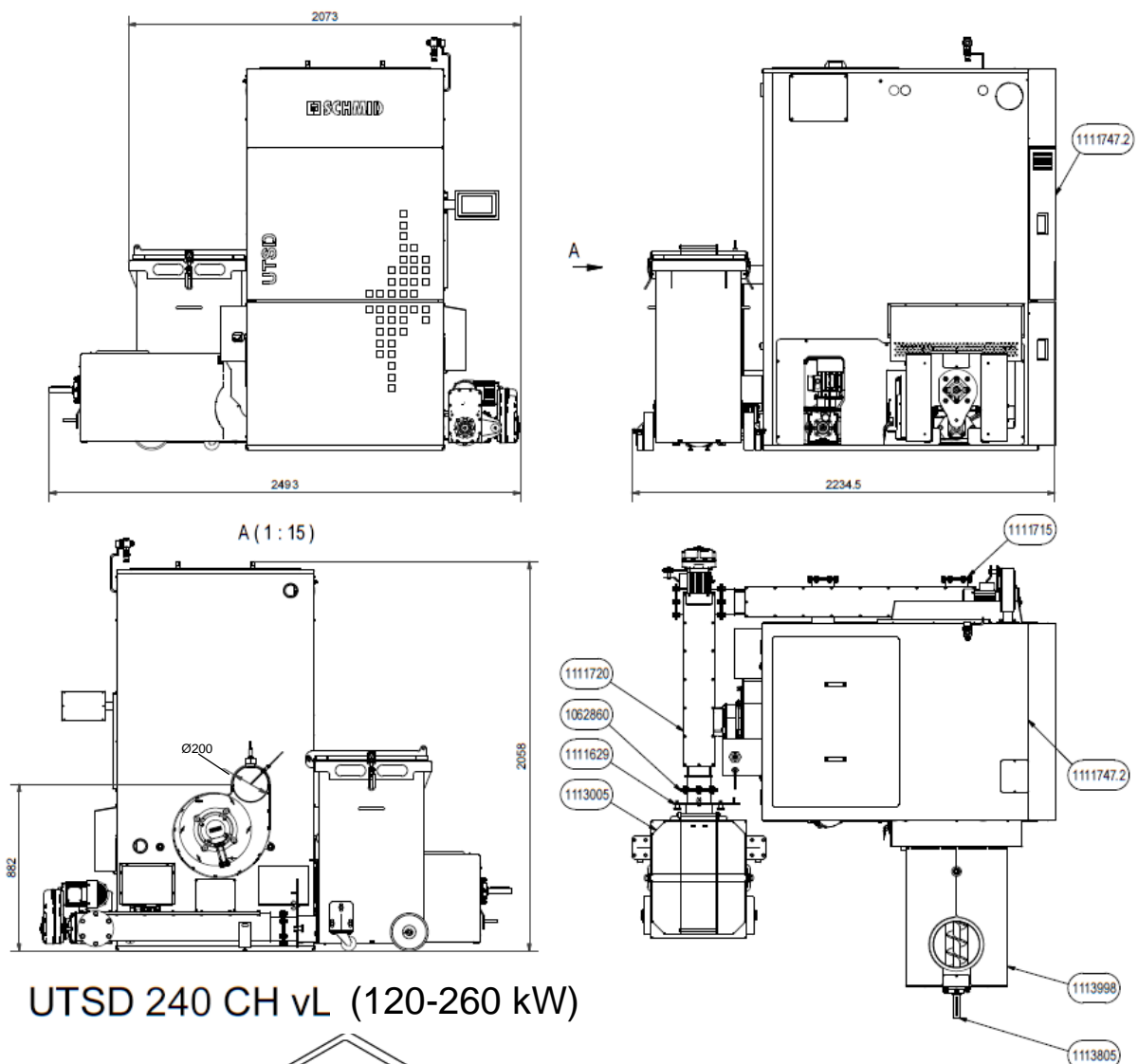

2.9.5 UTSD240/260 Stoker right, ash container 50l

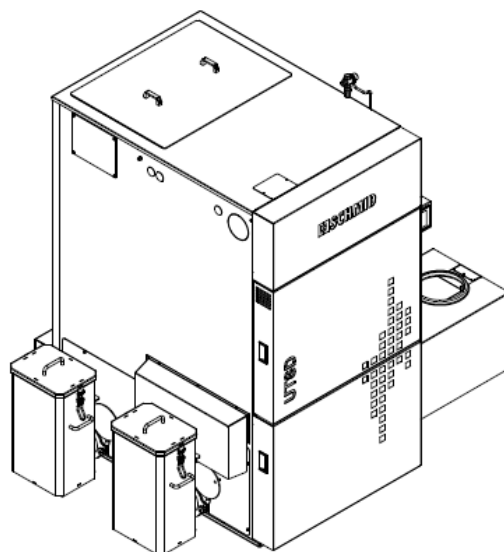
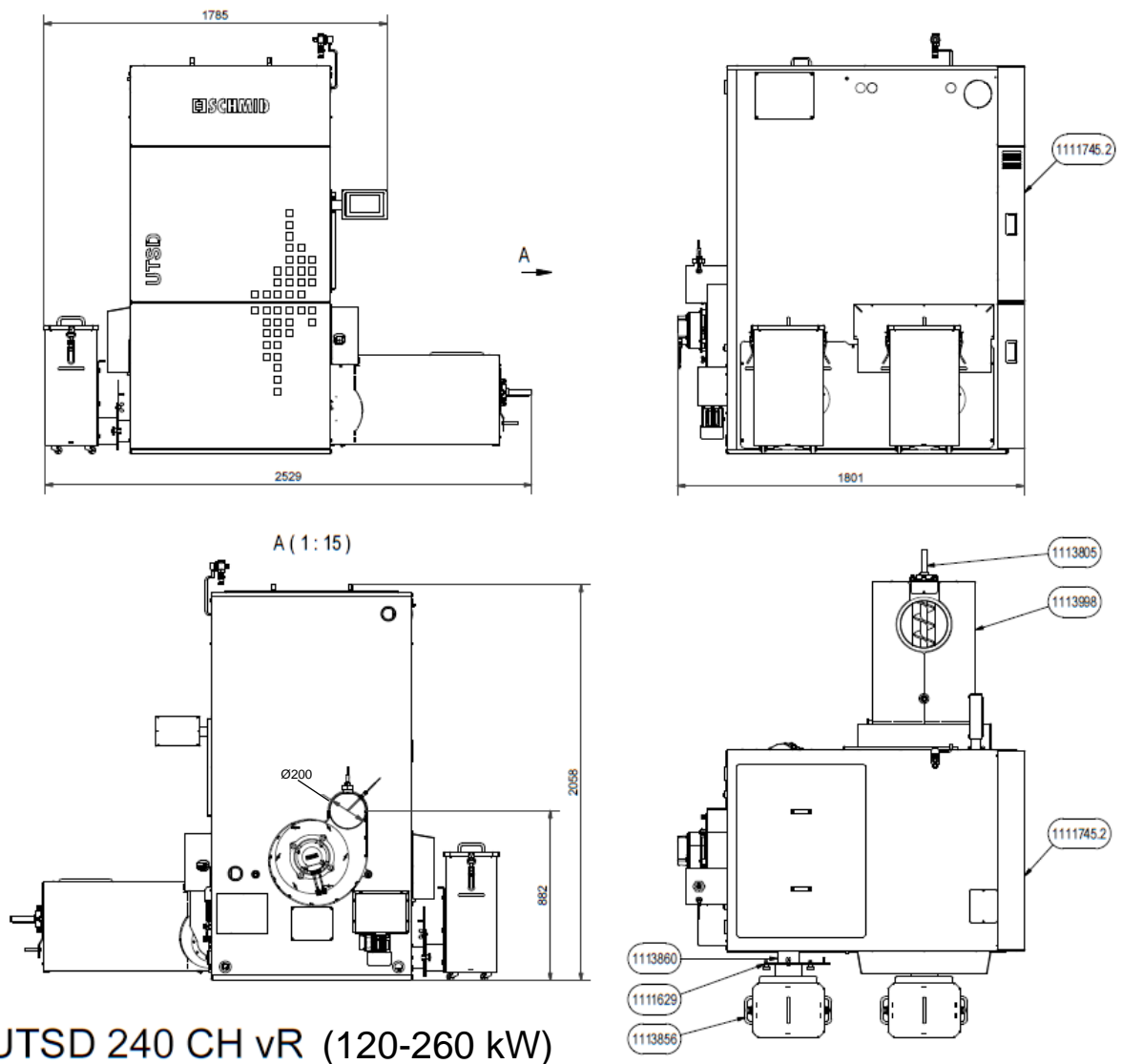

Wood chip and pellet combustion system UTSD 240

2.9.6 UTSD240/260 Stoker right, ash container 240l at rear

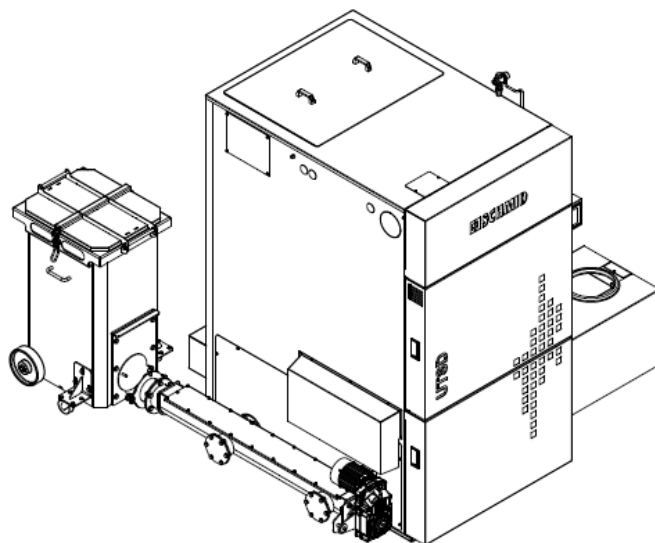
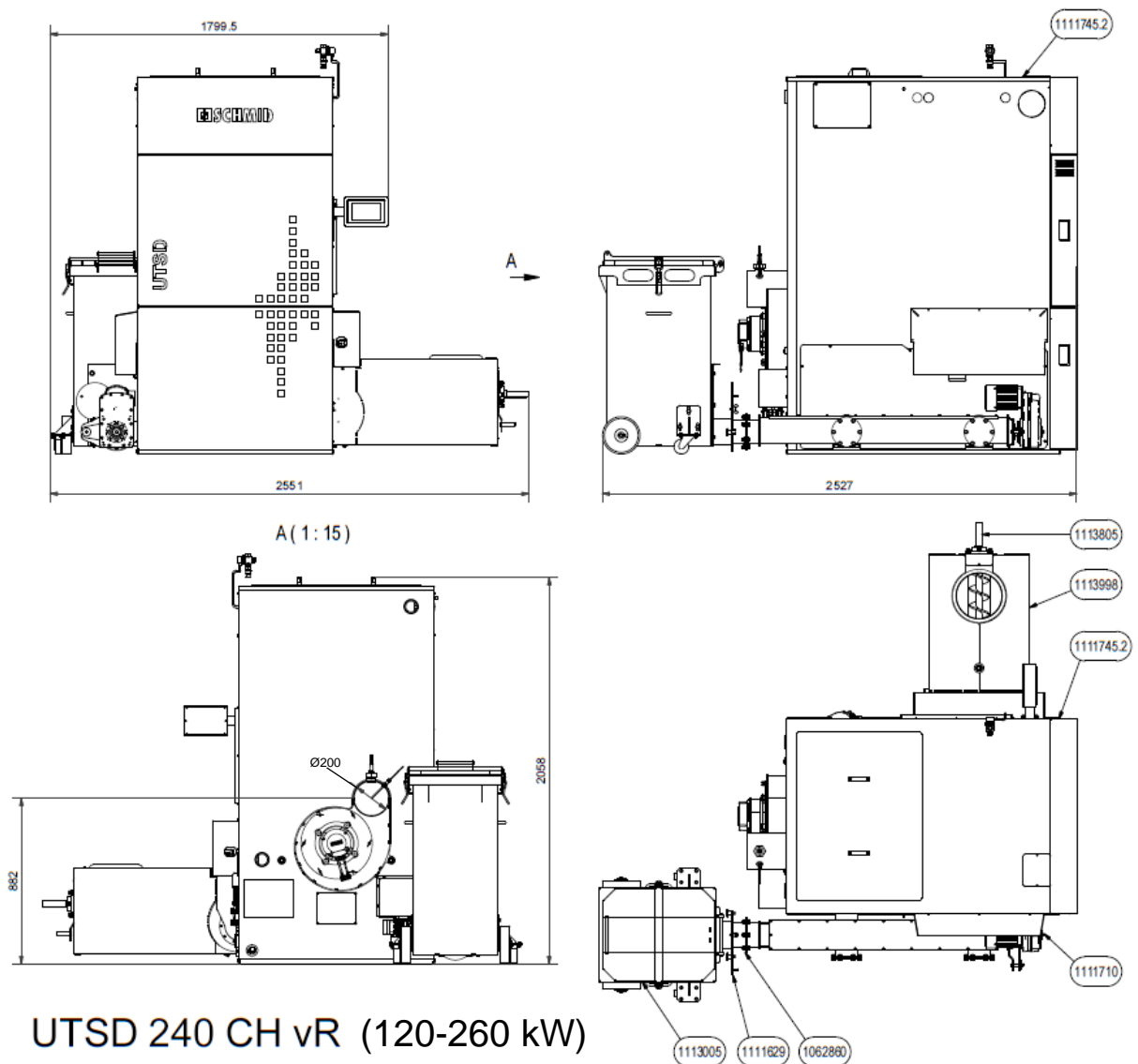

2.9.7 UTSD240/260 Stoker right, ash container 240l rear left

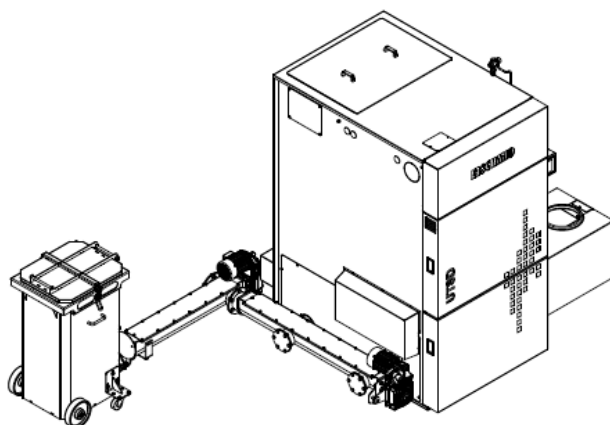
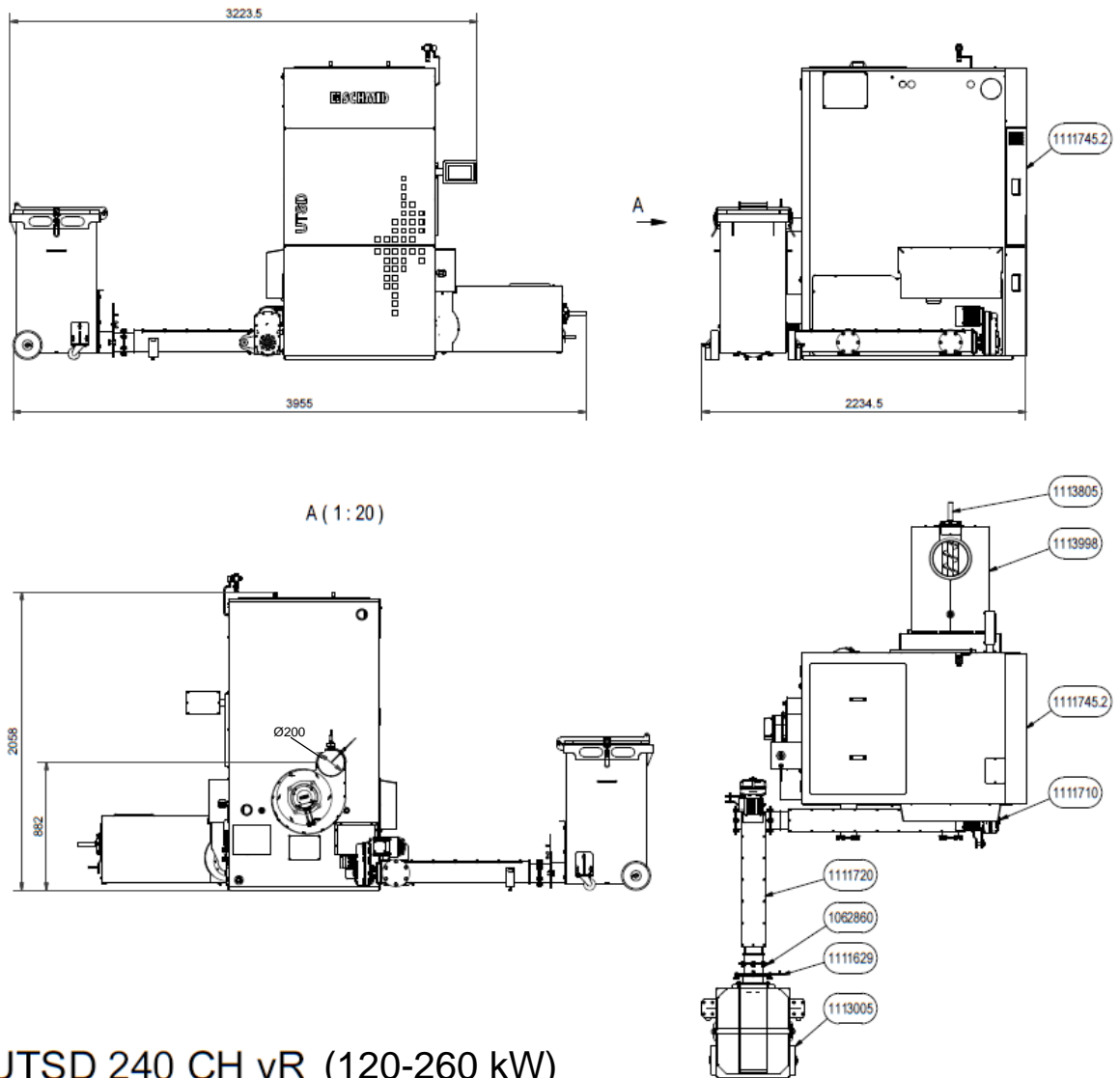

2.9.8 UTSD240/260 Stoker right, ash container 240l rear right

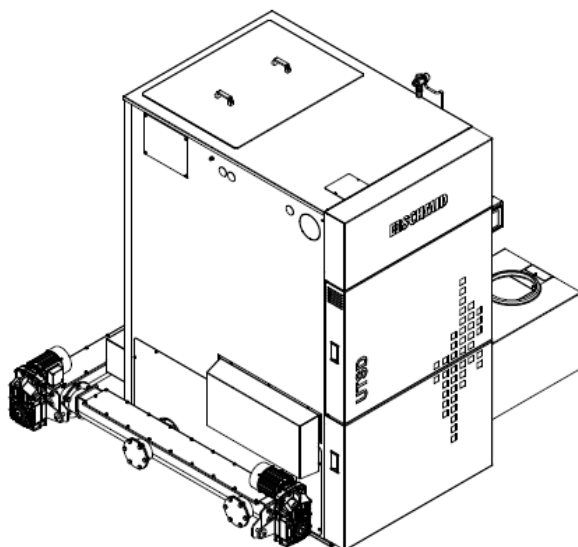
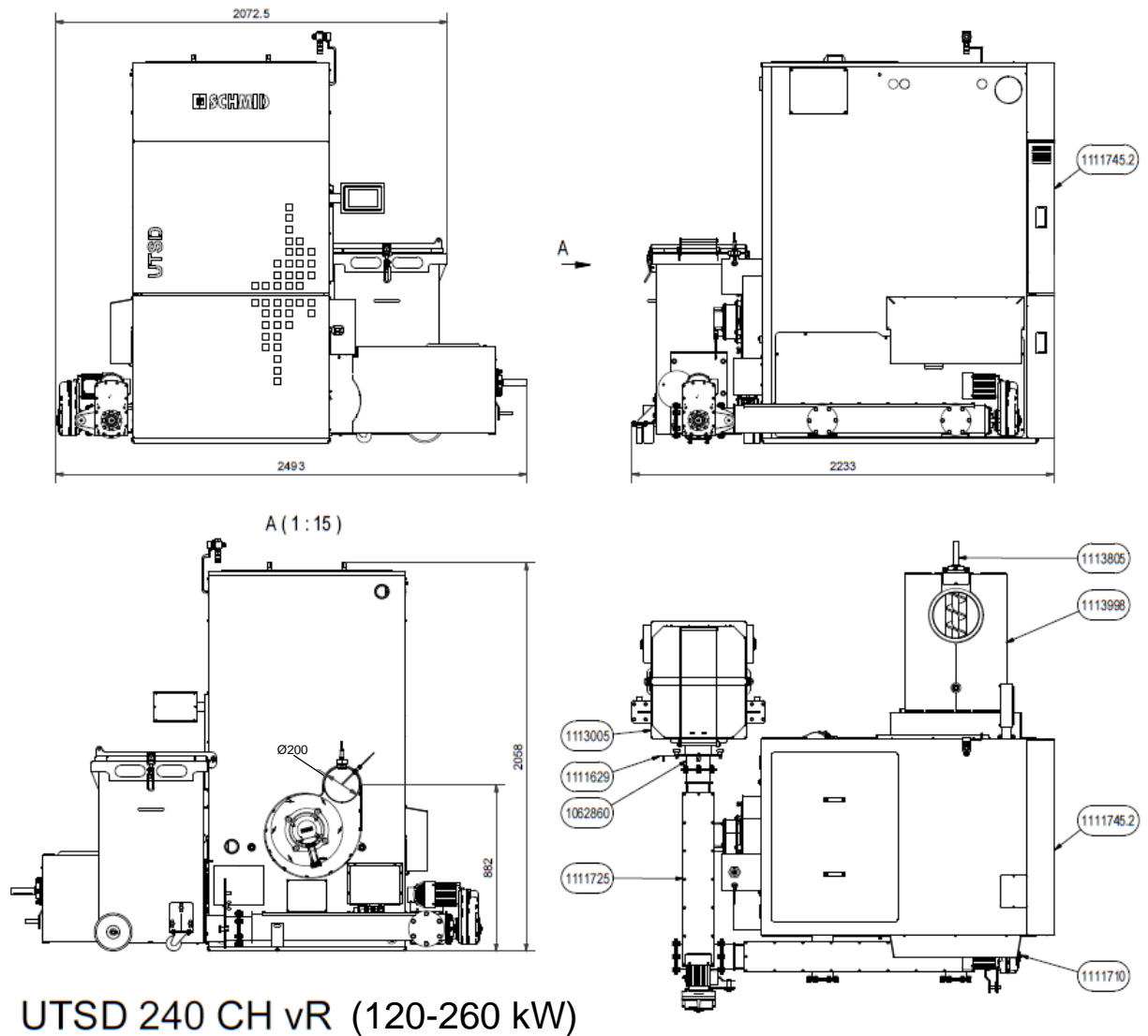

3 Fuel

3.1 Permissible fuel



The UTSD heating system is designed for standard use for burning natural wood in the form of wood chips, shavings or wood pellets.

With regard to the quality requirements for solid fuels, DIN EN ISO 17225 "Solid biofuels - Fuel specifications and classes"

- Part 4: "Classification of wood chips"
- Part 2: "Classification of wood pellets" applies.

Based on this standard, the properties of the fuels that can be used in the UTSD are specified in more detail below.

3.2 Wood chips

Particle size

Essential criteria for the definition of the property classes are particle size, water content and ash content of the fuel. Based on DIN EN ISO 17225-4, the particle size for wood chips is classified in the category P45S for wood chips, among others.

P-class	Main fraction (min. solid fraction 60%)	Fine fraction (weight %) ≤ 3.15mm	Coarse fraction (weight %) max. length, max. cross-section
P45S	3.15mm < P ≤ 45mm	≤ 10%	≤ 10% >63mm, all ≤ 150mm Cross section of the oversized particles ≤ 6cm ²

Medium wood chips with a particle size of up to 45 mm (P45S) are used more in larger systems, but may also be suitable for small systems depending on the diameter of the transport screw. Oversized pieces (end pieces) can lead to malfunctions during operation of the systems. A high fine fraction (dust) can lead to high emissions and the ejection of glowing particles.

With the UTSD, wood chips of category P45S can be used as fuel as described above. The maximum length of the oversized particles is limited to 150 mm.

Particle size

When selecting the fuel it must be taken into account that the heating value of the wood mainly depends on its water content. The more water there is in the wood, the lower the heating value, as the water evaporates during the combustion process and heat is consumed. This leads to a reduction in efficiency and therefore a higher wood consumption. In addition, as the moisture content of the fuel increases, an increasing reduction in boiler output, increased ash accumulation, smoke generation and reduced storage life can be expected.

The maximum permissible water content of the wood chips is 40% (M30). The water content of the wood chips may not be less than 10% (M10), as a higher aerosol formation leads to a higher dust value.

For technical considerations, a representative heating value is selected depending on the moisture content. For economical and emission-friendly combustion, the heating value should not be less than approx. 4 kWh/kg.

Water content	Moisture	Heating value	relative wood consumption
10.0 %	11.1 %	4.6 kWh/kg	87 %
20.0 %	25.0 %	4.0 kWh/kg	100 %
26.0 %	35.0 %	3.7 kWh/kg	110 %
30.0 %	42.9 %	3.4 kWh/kg	120 %

Ash content

A low ash content is required for environmentally friendly operation of the wood chip heating system. This minimises the content of combustion-critical elements. Aerosol-forming inorganic substances in wood such as potassium, chlorine or sodium are predominantly decisive for dust emissions during combustion. Such elements are mainly found in the needles, leaves and bark of a tree. Correctly prepared pure wood types such as coarsely debarked energy roundwood without needles, leaves and only a small proportion of bark have the lowest content of combustion-critical elements. They are therefore recommended for use in small combustion systems.

Ideally the ash content should not exceed 1.0 % by weight (A1.0) and therefore corresponds to property class A1. If wood chips with a higher ash content (property class A2 or B1/2) are used, the use of secondary measures (filter technology) to comply with the dust emission limit values according limit values according to 1.BImSchV (2nd level) is necessary.

3.3 Wood pellets

Wood pellets are cylindrical pressings. They comprise untreated chips and sawdust from the wood processing industry as well as virgin residual forest wood. They have a standardised diameter and a standardised length. They are pressed under high pressure and have a very low water content. The energy content of two kilos of pellets corresponds approximately to the energy content of one litre of heating oil.

Essential criteria for the definition of the property classes are length and diameter, water content and ash content of the fuel.

Length and diameter

The diameter of the pellets used must be suitable for use in the UTSD in connection with the D06 pellet suction system. When combined with another discharge system (e.g. for wood chips), the diameter can also correspond to D08.

- D06

The diameter of the pellets must be 6 mm +/- 1 mm. The length of the pellets must be between 3.15 mm and 40 mm. Up to 1.0 % by weight of the pellets may be up to 45 mm long.

- D08

The diameter of the pellets must be 8 mm +/- 1 mm. The length of the pellets must be between 3.15 mm and 40 mm. Up to 1.0 % by weight of the pellets may be up to 45 mm long.

Water content

The water content must be less than 10 % (M10) for property classes A1, A2 and B.

Ash content

The ash content of property class A2 or B is correspondingly higher than that of A1 due to the higher proportion of bark, needles and leaves. The ash content for property class A1 is 0.7 % by weight (A0.7), for property class A2 up to 1.2 % by weight (A1.2) and for property class B up to 2.0 % by weight (A2.0).

Alternatively, pellets with the "ENplus" or "DINplus" certificate are also suitable as they also meet the quality requirements of property class A1.

3.4 Permissible fuel according to EN303-5 version 2012-11-15

As defined in EN303-5 version 2012-11-15, the solid biofuels B1 and C1 may be used in this heating system.

Fuel B1

Wood chips (mechanically chopped wood, generally up to a maximum length of 15 cm), water content w of 15 % to 35 % in compliance with EN 14961-4

Fuel C1

Pressings (e.g. pellets without binding agents, made from wood and/or bark particles; natural binding agents such as molasses, plant-based paraffins and starch are permitted);
Pellets in compliance with EN 14961 -2

3.5 Permissible fuel in accordance with 1. BImSchV

According to article 3 (1) 1. BImSchV, fuel classes 4 and 5a may be used as fuel in this heating system.

Fuel class 4

Pieces of natural wood including attached bark, for example in the form of wood chips.

Fuel class 5A

Pressings of natural wood in the form of wood pellets or wood briquettes.

3.6 Nominal heat output depending on the water content

The following table shows the maximum nominal heat output depending on the water content in relation to the fuels specified in DIN EN ISO 17225 "Solid biofuels - Fuel specifications and classes", which are approved for the UTSD.

The table is only valid if the boiler is operated with fixed fuel and primary air quantities.

(No capacity adjustment by means of the combustion chamber temperature)



Please note:

The system is not intended for combustion of any fuel other than natural wood as described above, as this could result in damage to the system, such as corrosion, mechanical defects, and environmental damage (e.g. emissions of heavy metals). It is therefore strictly prohibited to use these non-approved fuels.

Combustion of wood with a high water content also has a negative effect on the efficiency and involves the risk of sooting or the formation of tar.

Failure to adhere to these specifications voids the warranty on system parts, mechanics and emissions.

Basis for wood chip energy content Önorm standard M7132 (mixed wood chips 50% spruce, 50% red beech)

	Wood chips M20 P45S A1.0	Wood chips M25 P45S A1.0 (A1.5)	Wood chips M30 P45S A1.0 (A1.5)	Wood chips M35 P45S A1.0 (A1.5)	Wood chips M40 P45S A1.0 (A1.5)	Pellets A1,A2
	kW	kW	kW	kW	kW	kW
UTSD240/110	---	---	---	---	---	110
UTSD 240/120	120	111	102	94	85	120
UTSD 240/140	140	130	120	109	99	140
UTSD 240/150	150	139	128	117	106	150
UTSD 240/160	160	148	137	125	113	160
UTSD 240/180	180	167	154	140	127	180
UTSD 240/200	200	185	171	156	142	200
UTSD 240/220	220	204	188	172	156	220
UTSD 240/240	240	222	205	187	170	240
UTSD 240/250	250	232	214	195	177	250
UTSD 240/260	260	241	222	203	184	260

4 Flue

4.1 Requirements

1. The flue must be inspected by the master chimney sweep responsible.
2. A flue dimensioned adequately for the boiler output and in accordance with country-specific standards (e.g. EN 1443, DIN 4705 or SIA 384/4, CH) is a prerequisite for proper and economical operation of the heating system.
3. Flue systems approved by the building inspectorate (in Switzerland VKF certified) must be installed.
4. The flue gas pipe between the boiler and the flue must be airtight and insulated.
5. The flue gas pipe must be routed into the flue at a minimum angle of 30°

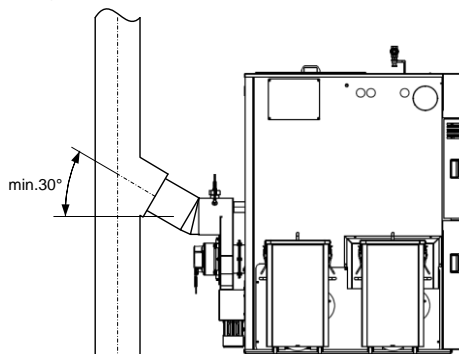

6. Flue gas temperature: With heating boilers run at a nominal heat capacity with a flue gas temperature of below 160K above the ambient temperature, the flue gas paths (flue gas pipe and flue) must be of moisture-resistant design to prevent sooting, insufficient conveying pressure and condensation in the flue path.
7. The flue pipe must be integrated into a lightning protection concept designed by a special company and installed in compliance with national standards (e.g. EN 62305-3).



The installation of a flue draught controller or a secondary air device is recommended for flue systems with a flue draught of above 20 Pa. If the flue system has a flue draught of below 20 Pa, no flue draught controller or a secondary air device should be installed.

4.2 Flue design data, wood chips

Make	UTSD 240/260		Blower:	Controlled induced draft			
Category	Solid fuel						
Fuel	Wood chips B1						
	Nominal capacity kW	Combustion capacity kW	CO2 content vol-%	Flue gas bulk flow g/s	Flue gas temperature °C	Minimum conveying pressure Pa	Flue gas connection D mm
Full load	260	281,5	12,6	159	131	8	200
Partial load	34,7	35,8	14,3	20	61	8	200

Make	UTSD 240/250		Blower:	Controlled induced draft			
Category	Solid fuel						
Fuel	Wood chips B1						
	Nominal capacity kW	Combustion capacity kW	CO2 content vol-%	Flue gas bulk flow g/s	Flue gas temperature °C	Minimum conveying pressure Pa	Flue gas connection D mm
Full load	250	269,9	12,4	153	128	8	200
Partial load	34,7	35,8	14,3	20	61	8	200

Make	UTSD 240/240		Blower:	Controlled induced draft			
Category	Solid fuel						
Fuel	Wood chips B1						
	Nominal capacity kW	Combustion capacity kW	CO2 content vol-%	Flue gas bulk flow g/s	Flue gas temperature °C	Minimum conveying pressure Pa	Flue gas connection D mm
Full load	240	258,7	12,3	148	125	8	200
Partial load	34,7	35,8	14,3	20	61	8	200

Wood chip and pellet combustion system

UTSD 240

Make	UTSD 240/220		Blower:	Controlled induced draft			
Category	Solid fuel						
Fuel	Wood chips B1						
	Nominal capacity kW	Combustion capacity kW	CO2 content vol-%	Flue gas bulk flow g/s	Flue gas temperature °C	Minimum conveying pressure Pa	Flue gas connection D mm
Full load	220	236,3	12,0	138	119	8	200
Partial load	34,7	35,8	14,3	20	61	8	200

Make	UTSD 240/200		Blower:	Controlled induced draft			
Category	Solid fuel						
Fuel	Wood chips B1						
	Nominal capacity kW	Combustion capacity kW	CO2 content vol-%	Flue gas bulk flow g/s	Flue gas temperature °C	Minimum conveying pressure Pa	Flue gas connection D mm
Full load	200	213,2	11,7	127	112	8	200
Partial load	34,7	35,8	14,3	20	61	8	200

Make	UTSD 240/180		Blower:	Controlled induced draft			
Category	Solid fuel						
Fuel	Wood chips B1						
	Nominal capacity kW	Combustion capacity kW	CO2 content vol-%	Flue gas bulk flow g/s	Flue gas temperature °C	Minimum conveying pressure Pa	Flue gas connection D mm
Full load	180	191,8	12,5	112	109	8	200
Partial load	34,7	35,8	14,3	20	61	8	200

Make	UTSD 240/160		Blower:	Controlled induced draft			
Category	Solid fuel						
Fuel	Wood chips B1						
	Nominal capacity kW	Combustion capacity kW	CO2 content vol-%	Flue gas bulk flow g/s	Flue gas temperature °C	Minimum conveying pressure Pa	Flue gas connection D mm
Full load	160	169,7	13,3	97	105	8	200
Partial load	34,7	35,8	14,3	20	61	8	200

Wood chip and pellet combustion system

UTSD 240

Make	UTSD 240/150		Blower:	Controlled induced draft			
Category	Solid fuel						
Fuel	Wood chips B1						
	Nominal capacity kW	Combustion capacity kW	CO2 content vol-%	Flue gas bulk flow g/s	Flue gas temperature °C	Minimum conveying pressure Pa	Flue gas connection D mm
Full load	150	158,7	13,8	89	103	8	200
Partial load	34,7	35,8	14,3	20	61	8	200

Make	UTSD 240/140		Blower:	Controlled induced draft			
Category	Solid fuel						
Fuel	Wood chips B1						
	Nominal capacity kW	Combustion capacity kW	CO2 content vol-%	Flue gas bulk flow g/s	Flue gas temperature °C	Minimum conveying pressure Pa	Flue gas connection D mm
Full load	140	147,7	14,2	81	101	8	200
Partial load	34,7	35,8	14,3	20	61	8	200

Make	UTSD 240/120		Blower:	Controlled induced draft			
Category	Solid fuel						
Fuel	Wood chips B1						
	Nominal capacity kW	Combustion capacity kW	CO2 content vol-%	Flue gas bulk flow g/s	Flue gas temperature °C	Minimum conveying pressure Pa	Flue gas connection D mm
Full load	120	122,5	15,2	64	97	8	200
Partial load	34,7	35,8	14,3	20	61	8	200

4.3 Flue design data, pellets

Make	UTSD 240/260		Blower:		Controlled induced draft		
Category	Solid fuel						
Fuel	Pellets C1						
	Nominal capacity kW	Combustion capacity kW	CO2 content vol-%	Flue gas bulk flow g/s	Flue gas temperature °C	Minimum conveying pressure Pa	Flue gas connection D mm
Full load	260	281,3	12,5	164	125	8	200
Partial load	32,2	33,1	14,7	16	54	8	200

Make	UTSD 240/250		Blower:		Controlled induced draft		
Category	Solid fuel						
Fuel	Pellets C1						
	Nominal capacity kW	Combustion capacity kW	CO2 content vol-%	Flue gas bulk flow g/s	Flue gas temperature °C	Minimum conveying pressure Pa	Flue gas connection D mm
Full load	250	268,4	12,4	158	121	8	200
Partial load	32,2	33,1	14,7	16	54	8	200

Make	UTSD 240/240		Blower:		Controlled induced draft		
Category	Solid fuel						
Fuel	Pellets C1						
	Nominal capacity kW	Combustion capacity kW	CO2 content vol-%	Flue gas bulk flow g/s	Flue gas temperature °C	Minimum conveying pressure Pa	Flue gas connection D mm
Full load	240	256,6	12,3	151	117	8	200
Partial load	32,2	33,1	14,7	16	54	8	200

Wood chip and pellet combustion system

UTSD 240

Make	UTSD 240/220		Blower:	Controlled induced draft			
Category	Solid fuel						
Fuel	Pellets C1						
	Nominal capacity kW	Combustion capacity kW	CO2 content vol-%	Flue gas bulk flow g/s	Flue gas temperature °C	Minimum conveying pressure Pa	Flue gas connection D mm
Full load	220	233,1	12,2	139	110	8	200
Partial load	32,2	33,1	14,7	16	54	8	200

Make	UTSD 240/200		Blower:	Controlled induced draft			
Category	Solid fuel						
Fuel	Pellets C1						
	Nominal capacity kW	Combustion capacity kW	CO2 content vol-%	Flue gas bulk flow g/s	Flue gas temperature °C	Minimum conveying pressure Pa	Flue gas connection D mm
Full load	200	207,9	12,0	126	103	8	200
Partial load	32,2	33,1	14,7	16	54	8	200

Make	UTSD 240/180		Blower:	Controlled induced draft			
Category	Solid fuel						
Fuel	Pellets C1						
	Nominal capacity kW	Combustion capacity kW	CO2 content vol-%	Flue gas bulk flow g/s	Flue gas temperature °C	Minimum conveying pressure Pa	Flue gas connection D mm
Full load	180	188,3	12,7	111	99	8	200
Partial load	32,2	33,1	14,7	16	54	8	200

Make	UTSD 240/160		Blower:	Controlled induced draft			
Category	Solid fuel						
Fuel	Pellets C1						
	Nominal capacity kW	Combustion capacity kW	CO2 content vol-%	Flue gas bulk flow g/s	Flue gas temperature °C	Minimum conveying pressure Pa	Flue gas connection D mm
Full load	160	167,2	13,5	94	95	8	200
Partial load	32,2	33,1	14,7	16	54	8	200

Wood chip and pellet combustion system

UTSD 240

Make	UTSD 240/150		Blower:	Controlled induced draft			
Category	Solid fuel						
Fuel	Pellets C1						
	Nominal capacity kW	Combustion capacity kW	CO2 content vol-%	Flue gas bulk flow g/s	Flue gas temperature °C	Minimum conveying pressure Pa	Flue gas connection D mm
Full load	150	156,7	13,9	86	93	8	200
Partial load	32,2	33,1	14,7	16	54	8	200

Make	UTSD 240/140		Blower:	Controlled induced draft			
Category	Solid fuel						
Fuel	Pellets C1						
	Nominal capacity kW	Combustion capacity kW	CO2 content vol-%	Flue gas bulk flow g/s	Flue gas temperature °C	Minimum conveying pressure Pa	Flue gas connection D mm
Full load	140	146,1	14,3	78	90	8	200
Partial load	32,2	33,1	14,7	16	54	8	200

Make	UTSD 240/120		Blower:	Controlled induced draft			
Category	Solid fuel						
Fuel	Pellets C1						
	Nominal capacity kW	Combustion capacity kW	CO2 content vol-%	Flue gas bulk flow g/s	Flue gas temperature °C	Minimum conveying pressure Pa	Flue gas connection D mm
Full load	120	125,1	15,1	62	86	8	200
Partial load	32,2	33,1	14,7	16	54	8	200

Make	UTSD 240/110		Blower:	Controlled induced draft			
Category	Solid fuel						
Fuel	Pellets C1						
	Nominal capacity kW	Combustion capacity kW	CO2 content vol-%	Flue gas bulk flow g/s	Flue gas temperature °C	Minimum conveying pressure Pa	Flue gas connection D mm
Full load	110	114,2	15,5	53	84	8	200
Partial load	32,2	33,1	14,7	16	54	8	200

5 Transport / securing



Warning!

Danger from suspended loads

If the heating boiler falls during transport, it can cause serious injury to personnel and it can become damaged. When erecting/transporting the heating boiler, ensure that you use suitable lifting gear to move the heating boiler.

5.1 Transport with a crane

1. Remove the packaging material from the heating boiler.
2. Remove the cover (1) of the heat exchanger connection from the boiler.
3. Open the access door to the heat exchanger and remove the cover (2).
4. Remove the deflection cover (3)

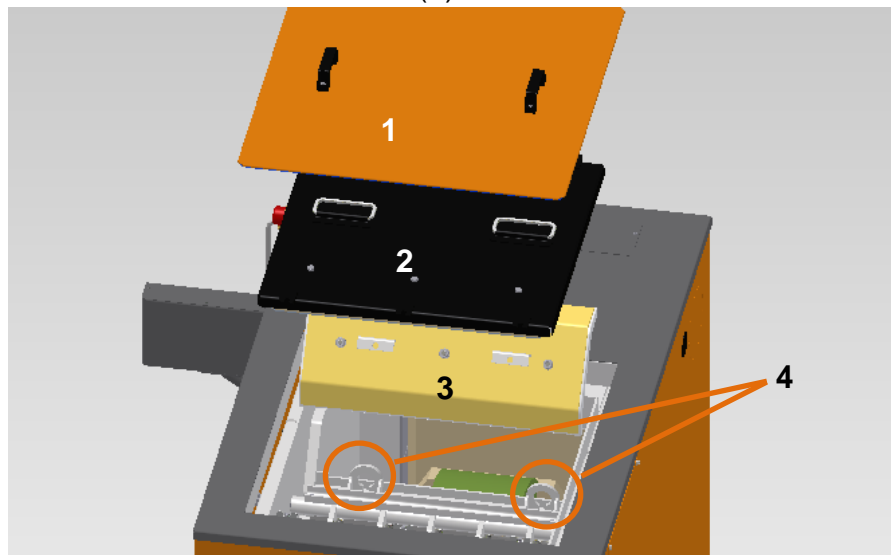

5. There are two crane eyes (4) under the deflection cover (3). These can be used to attach a transport hook.
6. Carefully lift the boiler and remove the wooden runners and transport timber.
7. Install the boiler at the planned installation site, observing the minimum distances.



Attention:

Observe the permissible bearing capacity of the employed lifting gear as well as lifting aids. The weight of the boiler is given in the **technical data**.

5.2 Transport with pallet truck

1. The boiler is delivered on two wooden runners connected with transport timbers so that it can be moved with a pallet truck.
2. Position the boiler at the planned installation site with the pallet truck, observing the minimum distances.
3. Remove the packaging material from the heating boiler.
4. Remove the black service covers (1) on the left and right-hand sides of the boiler.
5. There is a screw (2) at each boiler base corner. You can use these to lift the boiler and relieve the load on the wooden runners.

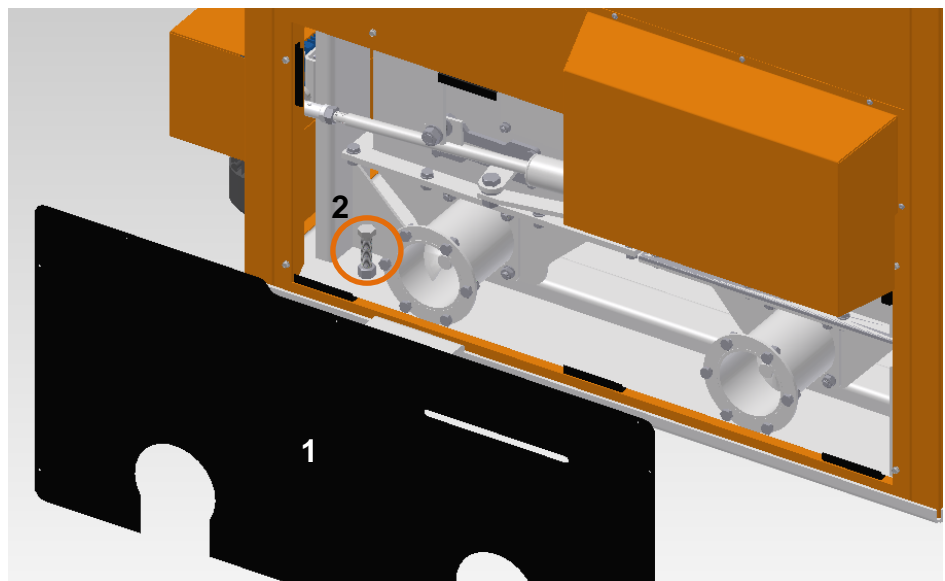

6. Remove the wooden runners and the transport timbers and place the boiler back on the floor using the screws.

5.3 Aligning the boiler

Check that the boiler is horizontal. If not, you can use the screws at the bottom of the boiler to adjust its position.



A slightly forward tilted boiler orientation is favourable for easier venting of the hydraulic system.

6 Electrics / mains cable / external units

6.1 Regulations

The regulations of the 2014/35/EU (Low Voltage Directive) must be observed for the electrical connection of the system. The electrical connection must be made at a separate, all-pole disconnecting device with at least 3 mm contact spacing. The fuel storage room should never contain any electrical installations such as sockets, distribution boxes, light lamps or light switches. Light fixtures must be explosion-proof. The VDE regulations for dust-prone rooms must be observed.

6.2 Cable routing

The control is integrated in the side wall of the boiler. The mains supply line and cables from external units are routed through the rear wall of the boiler and must be configured as shown in the figure below. Strain on the cables must be relieved by means of cable ties on the mesh cable tray and at the lugs provided.

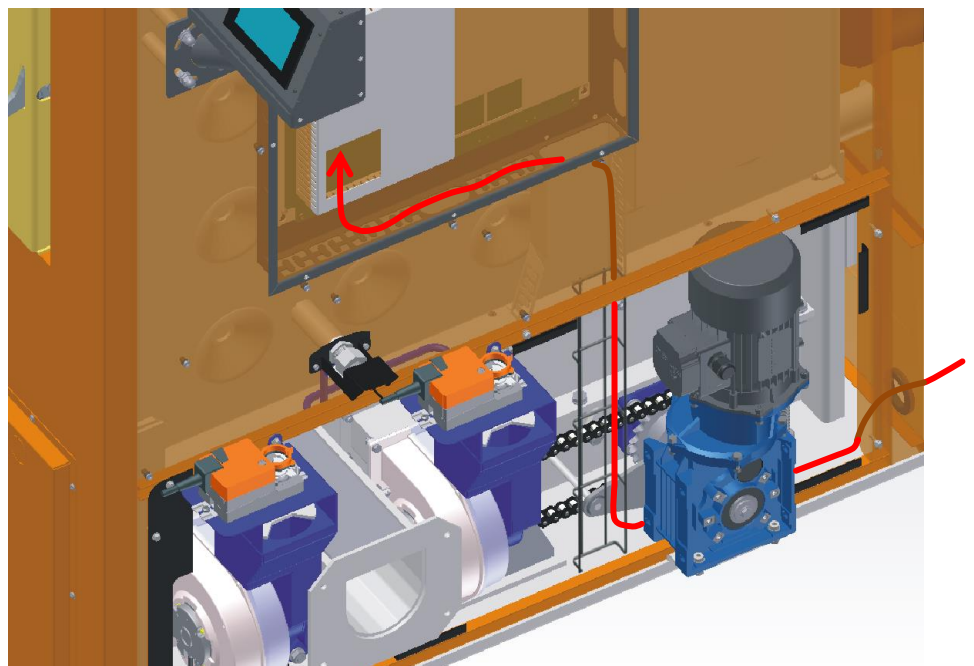

6.3 Mains connection

The mains supply line must be connected directly to the mains filter and the earthing terminal provided to this purpose.

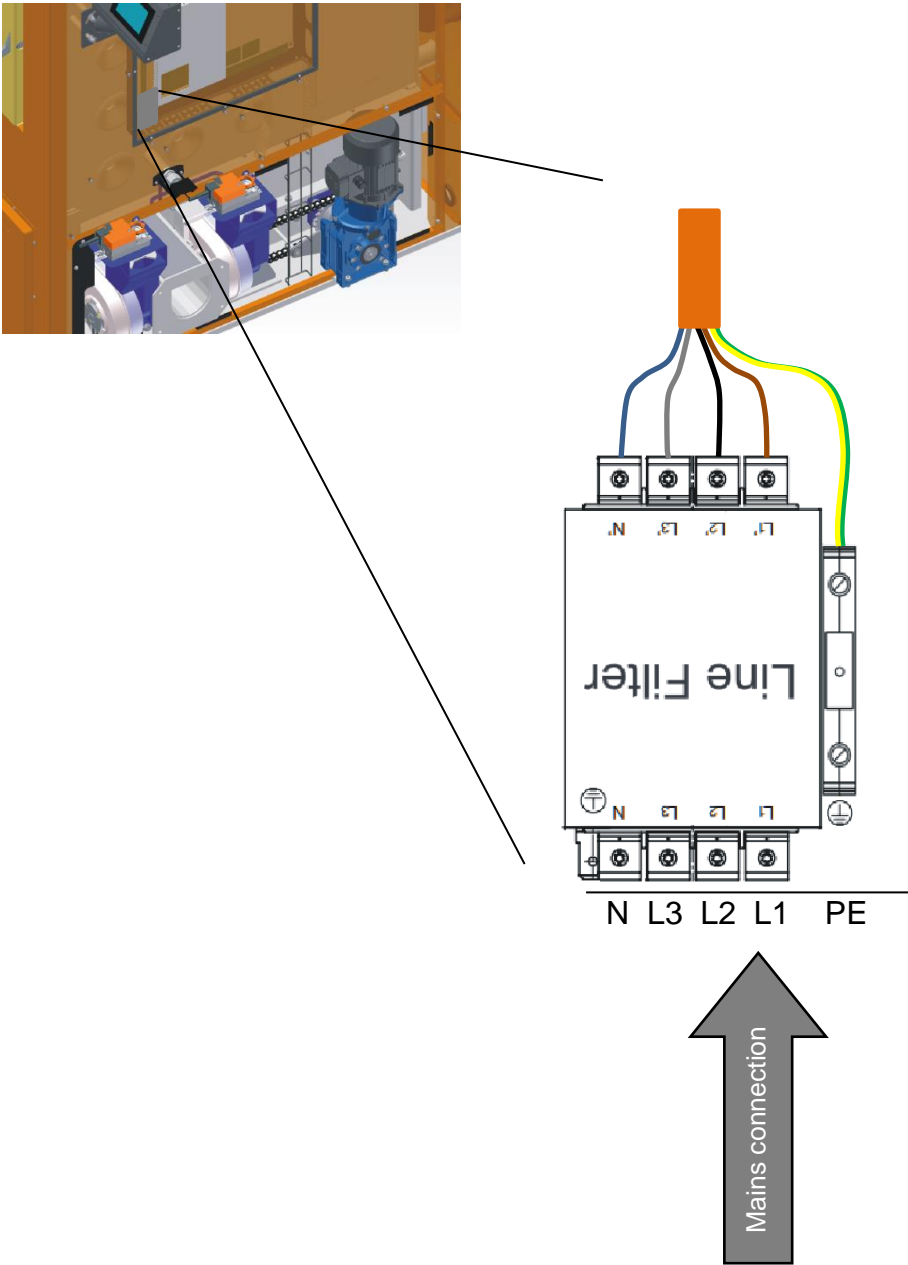

7 Hydraulic requirements

7.1 Requirements for circulating water up to 110°

In order to prevent damage, particularly resulting from scaling in the boiler system, circulating water in new and refills must always fulfil the following conditions: (SWKI Directive 97-1):

Characteristic	Value	Notes
Total water hardness	Max 0.2° f Max 0.1° dH	1° f = French degree of hardness, respectively 0.56 °dH = German hardness equal to 10 mg/l calcium carbonate per litre of water
PH-value at 20°C	8,5 ... 9,5	
Phosphates (PO4)	30 mg/l max.	
Chlorides (Cl)	30 mg/l max.	
Oxygen (O2)	0.1 mg/l max.	Hot water up to 110° C

Water treatment for different types of raw water



- Up to 20°f → Add hardness stabilisers and an alkalisating agent
- Above 20°f → Softening through ion exchange to 0° f hardness and addition of an alkalisating agent. Large systems (e.g. piped heating networks) may require complete softening and alkalisation.
- The circulating water must be checked annually. Furthermore the valid national standards must be complied with.



Attention:

To prevent damage to safety equipment during filling or replenishing, the inlet water pressure must be limited to the permissible operating pressure, refer to the **technical data**.

7.2 Temperature relief valve (TAS)

When integrating the boiler unit in a closed heating system, the temperature relief valve is responsible for ensuring that the heat from the boiler is discharged through the cooling water; heat can develop due to, for instance, a defect in the open loop/closed loop control system and associated continued burning at nominal load or in the event of a power outage with a natural draft fire resulting from it.



The equipment for removing excessive heat has to be serviced and tested once a year by a qualified person.

The water supply must be ensured at all times.

A drinking water system separator has to be integrated into the extinguishing water supply in accordance with country-specific regulations.



Caution!

Make sure that the runoff from the temperature relief valve is drained by routing it through a temperature-resistant line to avert scalding!

The heat exchanger must not be used as a water heater.

Temperature relief valve connection pictorial schematic

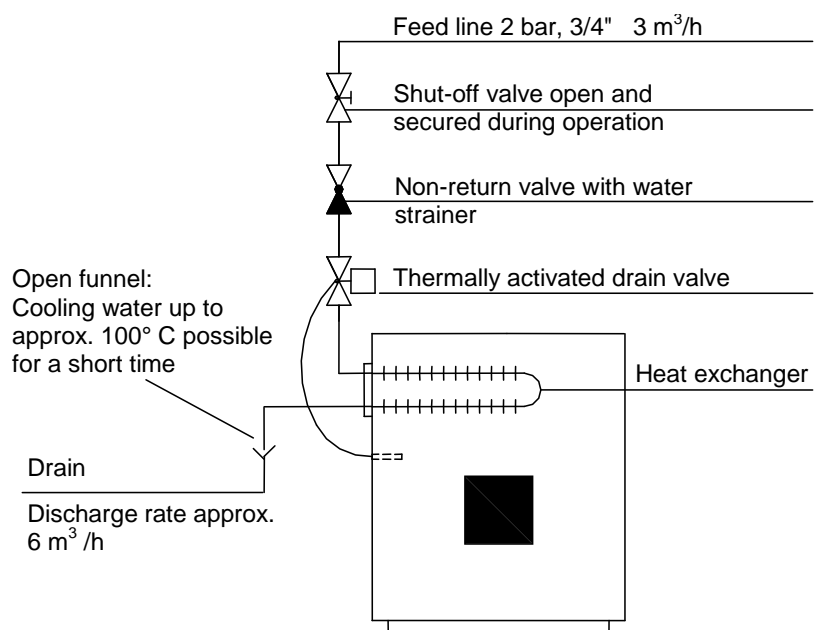

7.3 Thermally activated extinguishing system

A thermally activated valve with contact sensor (electrically independent) needs to be installed and the contact sensor positioned directly next to the stoker on the protective pipe designed for it. If the temperature in the stoker is $>65^{\circ}\text{C}$, the extinguishing water valve opens automatically and the backfire is extinguished. The extinguishing water valve closes automatically if the temperature drops back below the trip point.

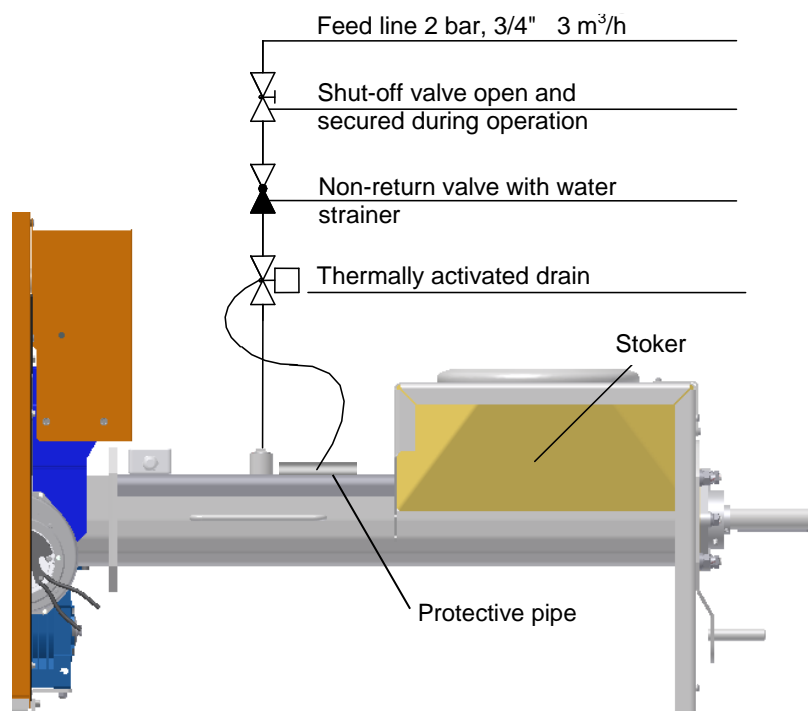

The thermally activated extinguishing system has to be serviced and tested once a year by a qualified person.

The water supply must be ensured at all times.

A drinking water system separator has to be integrated into the extinguishing water supply in accordance with country-specific regulations.

7.4 Accumulator

Use of a buffer tank When calculating the heat requirement of buildings, e.g. according to DIN EN 12831 "Method for calculation of the design heat load", the lowest outside temperature of the respective climate zone (e.g. -15 °C) is assigned. However, these conditions only prevail on a few days a year, so that a heating system is oversized in terms of its heat output on most heating days. For this reason, the UTSD heating system is equipped as standard with a capacity control and automatic ignition system.



It is, however, highly recommended that a buffer tank is also used in automatic combustion systems.

The size of the buffer tank depends on the nominal heat output of the boiler and the heat requirement of the building. A reference value of 25 litres per kilowatt of boiler output can be used. This results in a boiler combustion time of approx. 1.25 hours at full-load operation, during which the buffer tank is completely filled. The discharge time of the buffer storage tank at 25% nominal load is approx. 4 hours in this design case, with an assumed usable temperature difference of 40 Kelvin. One advantage of using a buffer storage tank is the low operating hours of the system and fewer start-up phases due to longer heating intervals, which leads to a low proportion of external energy and low wear of mechanical parts.

Another advantage of a buffer storage tank is that it can be used in summer operation, i.e. only for domestic hot water preparation. In this operating mode, frequent on/off operation is avoided by a buffer storage tank.



For the reasons listed above, we also recommend a buffer storage tank for automatic combustion systems.

Country-specific requirements:

Clean Air Ordinance (LRV) The minimum storage volume is defined as follows in accordance with the Swiss Ordinance on Air Pollution Control (LRV) of 16 December 1985 (as of 16 April 2019):

Automatic boilers up to 500 kW nominal heat output must be equipped with a heat storage tank with a volume of at least 25 litres per kW nominal heat output. Excluded from this are boilers for wood pellets up to 70 kW combustion capacity.

This results in the following minimum storage volumes:

UTSD (wood chips / pellets)	Min. buffer storage tank
240/110	2750 l
240/120	3000 l
240/140	3500 l
240/150	3750 l
240/160	4000 l
240/180	4500 l
240/200	5000 l
240/220	5500 l
240/240	6000 l
240/250	6250 l
240/260	6500 l

The authorities may specify smaller buffer tank storage sizes if this is appropriate for technical or operational reasons.

If several individual combustion systems are operated as an operational unit for the purpose of covering variable heat requirements in alternating constellations, the authorities may specify smaller storage tank sizes.

7.5 Hydraulic integration



The pipe dimensions must be adapted to site conditions. Pay attention to the connection of the heating boiler on the water side for the supply and return lines.

The dimension and routing of the pipes is determined by the heating system planner or heating engineer. The pump and valve size must be adapted if necessary to suit the pipe lengths and static heights (e.g. boiler installation site).

Increasing the return line temperature

Installation of a return temperature control group is essential, as the control behaviour of the boiler in connection with the AutomaticControl is not correct without a hydraulic group. As a general rule, insufficient operating temperatures shorten the service life of the heating boiler considerably. The water steam contained in the flue gas is separated as condensate when the temperature drops below the dewpoint, in particular in the area of the water-cooled downstream heating surfaces, where the flue gas temperatures are already relatively low. This condensate causes corrosion and shortens the service life of the heating boiler. Corrosion caused by condensate formation is prevented by the following measures:

- The flow temperature is maintained by the controller.
- The return line temperature is kept above the dewpoint by the mandatory return temperature control group.